

Acceleration and increase of hydrogen production by simultaneous fermentation of *Clostridium butyricum* and *Rhodobacter sphaeroides* on wine-vinasse substrate

M. Krysteva^{1*}, I. Lalov¹, V. Beschkov²

¹ Department of Biotechnology, University of Chemical Technology and Metallurgy
8 Kliment Ohridski Blvd., 1756 Sofia, Bulgaria

² Institute of Chemical Engineering, Bulgarian Academy of Sciences,
Acad. G. Bonchev St., Block 103, 1113 Sofia, Bulgaria

Received February 9, 2009; Revised August 12, 2009

A fermentation process for hydrogen production as a result of the simultaneous effect of *Rhodobacter sphaeroides* and *Clostridium butyricum* on a wine-vinasse substrate was realized in a single illuminated bioreactor. The kinetics of the cooperative process indicates rapid and enhanced production of hydrogen showing yield of 65.41 mmol/l vinasse with a mixed culture as compared to processes using the two bacteria separately that have yields of 27.41 and 25.49 mmol/l vinasse for *Rhodobacter* and *Clostridium*, respectively. The experiment with a mixture of the two bacteria revealed co-operative assimilation of almost all components studied in the following sequence: malic acid > lactic acid > residual sugars > tartaric acid > citric acid. The use of vinasse substrate for hydrogen production would be a significant ecological energy resource for enterprises producing wine brandies together with waste utilization.

Key words: hydrogen production, mixed fermentation, *Rhodobacter sphaeroides*, *Clostridium butyricum*, renewable energy resource, wine-vinasse.

INTRODUCTION

In the nearest future hydrogen is expected to find a wide application in both industry and transport because water is the only product of its burning. In addition to the labour-consuming and expensive methods of its chemical preparation, biological methods became very popular during the past years.

Methods based on photo-fermentation and dark-fermentation H₂-producing bacteria on various substrates proved very important. One of the main problems with these bacterial processes is the substrate material which is, in most cases, an agricultural waste product, waste water, whey, *etc.*, needing sometimes additional pre-treatment before being thrown away [1, 2]. The utilization of these products aimed at hydrogen production would result in cheap and pure energy, the polluting waste products being eliminated. Some studies used carbohydrate-containing substrates and dark-fermentation with the participation of bacteria, above all of the kind *Clostridium* [3, 4] as well as photo bacteria acting on substrates which contain mainly organic acids were carried out [5, 6]. Combination of the two processes has been achieved by successive utilization of a glucose-containing substrate with *Enterobacter cloacae* followed by photofermen-

tation with *Rhodobacter sphaeroides* of the metabolites from the dark process which contain, mainly acetic acid and other products. This combination of the two processes significantly increases the hydrogen yield and the utilization of the substrate chemical energy. The hydrogen yield of the combined processes is found to be higher than that of a single process [7]. The development of an integrated biological hydrogen production process is described on the basis of unicellular green algae, which are driven by the visible portion of the solar spectrum, coupled with purple photosynthetic bacteria, which are driven by the near infrared portion of spectrum [8].

In the present study, we tried to obtain hydrogen by simultaneous photo fermentation and dark fermentation in a single bioreactor with combined action of *Chlostridium butyricum* and *Rodobacter sphaeroides* on the waste substrate. The latter, called wine-vinasse, was a waste product formed during wine distillation before obtaining brandy as a final product. This product is rich in organic acids and residual sugars, amino acids and small amounts of other compounds coming from the grapes.

MATERIALS AND METHODS

Cultivation of Rhodobacter sphaeroides and Clostridium butyricum

Clostridium butyricum 1389 strain was supplied from the National Bank of Industrial Microorga-

* To whom all correspondence should be sent:
E-mail: krysteva@uctm.edu

nisms and Cell Culture in Sofia. The initial *Rhodobacter sphaeroides* strain was bought from the firm NCIMB, UK with an authentic certificate.

Rhodobacter sphaeroides was cultivated in M₂₂ medium [9] containing sodium lactate, succinate, glutamate and aspartic acid as carbon and nitrogen sources as well as minerals and vitamins. Cultivation was performed under anaerobic conditions in light at a temperature of 30°C and pH 6.5. The cells grown were colored in red. Prior to its use, the culture was adapted in vinasse, at first in a 1:1 ratio, and then on pure vinasse.

Clostridium butyricum was precultured at 37°C in a basal medium (pH 7.0) containing (g/l) casein hydrolyzate 15 g, L-cystein 0.5 g, glucose 5.0 g, yeast extract 5 g, sodium thioglycolate 0.5 g, sodium chloride 2.5 g and agar 0.75 g. Before using the culture to obtain hydrogen from vinasse, it was adapted in a nutrient medium and vinasse in a 1:1 ratio, after which it was transferred to pure vinasse.

Vinasse substrate was prepared by distillation of white wines and consisted mainly of tartaric acid, citric, malic and lactic acids, amino acids, residual sugars as well as other compounds of lower contents. When vinasse from red wines were used, the residue after the alcohol distillation was decoloured with active carbon in order to eliminate dyeing substances.

Assays

Analysis of acids were performed with a HPLC chromatography (HPLC Waters column Lichrosper 100, RP-C₁₈). The sugars were determined spectrophotometrically as reducing substances by means of 3,5-dinitrosalicylic acid [10]. Quantitative estimation was made on the basis of a standard straight line obtained using glucose and the above method.

The cell concentration in this case was also determined nephelometrically at 600 nm and then recalculated per mg dry weight with the use of a standard calibrating curve.

Hydrogen gas was estimated using an electrochemical gas sensor TGS-FIGARO Engineering Inc., based on tin dioxide as sensing material. The output signal displayed the percentage volume of H₂ in a biogas mixture. The system was calibrated once in two days using pure hydrogen calibration gas.

Procedure of hydrogen production

Hydrogen is produced from both single pure cultures and the mixed cultures in the laboratory installation shown in Fig. 1.

Vinasse substrate (150 ml) was placed in a glass bioreactor with a volume of 200 ml and flat walls ensuring better illumination. Inoculated and adapted

Rhodobacter sphaeroides culture was added during the single experiments in amounts of 20 ml so that the final concentration in the total working volume was about 0.4 mg/ml dry cells. In the case of *Clostridium butyricum*, an inoculate of its cells adapted to wine-vinasse in a volume of 20 ml was added to 150 ml of the substrate with a view to achieving a final concentration of about 0.2 mg·ml⁻¹ dry cells in the working volume of the reactor. The biomass concentration in the mixed culture of the two microorganisms was the same as with the experiments with one bacterial kind (*R. sphaeroides* 0.4 mg·ml⁻¹ *C. butyricum* 0.2 mg·ml⁻¹, i.e. a ratio of 2:1 between them taking into consideration that organic acids content is higher in vinasse than reducing sugar compounds). With both kinds of experiments the pH value was 6.5 and this value was maintained during the whole process at a temperature of 30°C. Immediately after introducing the inoculate, the whole system was blown through with argon for 15 min to ensure an anaerobic medium. After this procedure, the halogen lamp of 500 W was switched on in order to illuminate the reactor. The bioreactor content was stirred with a magnetic stirrer and the adsorption of carbon dioxide before hydrogen accumulation proceeded in a 10% Ca(OH)₂ solution.

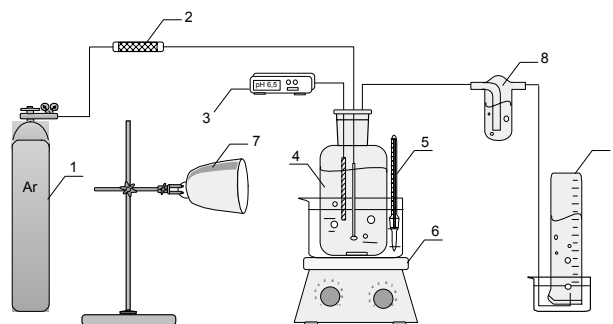

Fig. 1. Laboratory scheme for photo production of hydrogen by *Clostridium butyricum* and *Rhodobacter sphaeroides*. 1 - argon; 2 - microbial filter; 3 - pH-meter; 4 - photobioreactor; 5 - temperature control; 6 - magnetic stirrer; 7 - halogen lamp; 8 - CO₂ trap (10% Ca(OH)₂); 9 - gasholder.

RESULTS AND DISCUSSION

Photo fermentation process for hydrogen production using *Rhodobacter sphaeroides* and waste wine-vinasse substrate

Fig. 2. shows the kinetics of hydrogen production in a periodic photo fermentation process.

Hydrogen evolution was observed for 115 h. Hydrogen generation began approximately during the fifth hour from the process beginning and had its highest rate of 163.79 μmol·h⁻¹ until the 23th hour,

then continued with a rate of $49.05 \mu\text{mol}\cdot\text{h}^{-1}$ up to the 68th h. After that, the rate of biohydrogen production gradually dropped until abating of the process 96 h after its start probably due to exhaustion of the substrate. During these 96 h the volume of hydrogen amounted to 5.612 mmoles, i.e. the mean rate of its generation was $59.03 \mu\text{mol}\cdot\text{h}^{-1}$. Along with the fermentation process, the increase in biomass was also followed. The cell biomass introduced with the inoculate, was found to grow from $0.42 \text{ mg}\cdot\text{ml}^{-1}$ to $0.997 \text{ mg}\cdot\text{ml}^{-1}$ in the exponential phase of the growth curve, these investigations being also presented in Fig. 2. The productivity curve (Fig. 2) shows the maximum in the late exponential phase of the microbial growth followed by sharp decrease, with a relatively low productivity in the stationary phase.

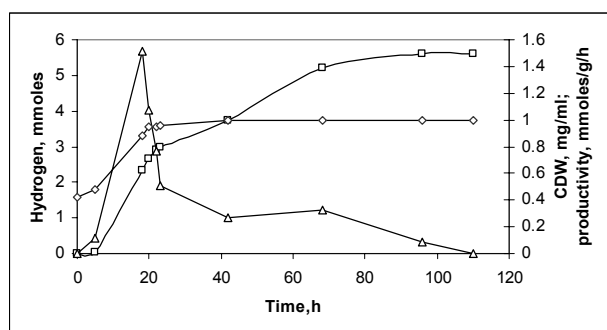

Fig. 2. Kinetics of hydrogen production, microbial growth and productivity at photo fermentation process with *Rhodobacter sphaeroides* and vinasse as a substrate. (-◇-) – CDW (cell dry weight); (-△-) – hydrogen; (-□-) – productivity.

Hydrogen production using *Clostridium butyricum* and waste wine-vinasse substrate

The batch fermentation process of hydrogen production by means of *Clostridium butyricum* was realized under conditions identical to those of the above process, however without illumination. Fig. 3, illustrating the process kinetics, evidences noticeable hydrogen production about the 10th h. The process continued with a constant high rate of $120.55 \mu\text{mol}\cdot\text{h}^{-1}$ till the 32th h, after which a rapid rate drop was noticed. The process preserved its intensity till the 50th h (Fig. 3). The same plot demonstrates a biomass increase from $0.2 \text{ mg}\cdot\text{ml}^{-1}$ to $0.71 \text{ mg}\cdot\text{ml}^{-1}$ at the end of the process. For the strain *Clostridium butyricum* the maximum productivity was observed in the all phases of growth, with a maximum in the stationary one (Fig. 3)

Probably, for hydrogen production in the stationary phase a substrate available in the growth phase is necessary.

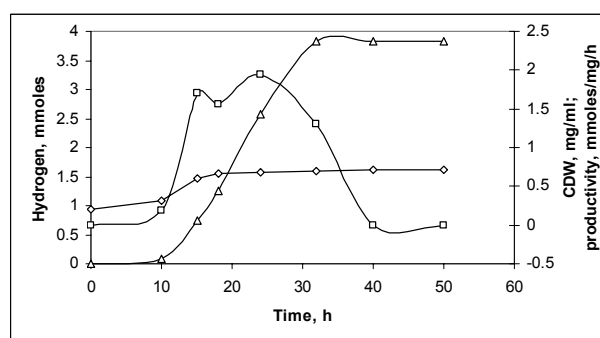

Fig. 3. Kinetics of hydrogen production and microbial growth at fermentation process with *Clostridium butyricum* and vinasse as a substrate. (-◇-) – CDW (cell dry weight); (-△-) – hydrogen; (-□-) – productivity.

A periodic photo fermentation process for hydrogen production using the joint effect of *Rhodobacter sphaeroides* and *Clostridium butyricum* on wine-vinasse as a substrate

Vinasse substrate in an amount as already used separately with the two microorganisms (*Rh. sphaeroides* and *C. butyricum*) was placed in the above reactor together with them taking into account the necessary condition of their having a 2:1 ratio in the working volume. The process was accompanied by illumination. Fig. 4 shows the kinetics of hydrogen production in the presence of both bacteria as well as biomass growth and productivity.

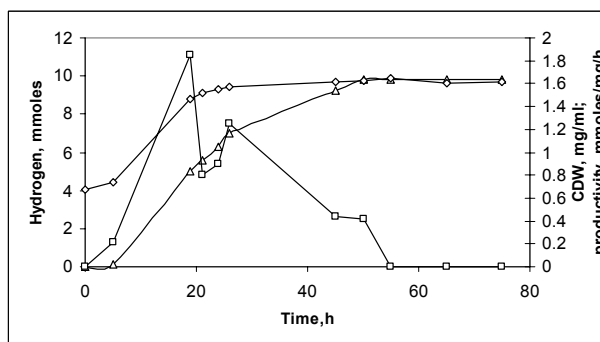

Fig. 4. Kinetics of hydrogen production and microbial growth at photo fermentation process with mixed culture of *Rhodobacter sphaeroides* and *Clostridium butyricum* and vinasse as a substrate. (-◇-) – CDW (cell dry weight); (-△-) – hydrogen; (-□-) – productivity.

Evidently, the production of hydrogen begins relatively soon (during the 5th h after the process beginning) and the rate increases quickly till the 26th h with an average rate of $326.74 \mu\text{mol}\cdot\text{h}^{-1}$. Hydrogen generation was observed for 50 h. but already with a lower rate of $117.64 \mu\text{mol}\cdot\text{h}^{-1}$. The total gas production was 9.811 mmoles, i.e. much more than the productions in the previous batch processes. During the 75th h the intensity of hydrogen production was still high.

It is obvious that hydrogen production takes place within the whole time for culture growth tending to zero when the substrate is probably exhausted. The results show the possibility of co-operating the two bacteria in order to enhance the hydrogen production and achieve better utilization of the vinasse substrate.

Analysis of the utilized components of the vinasse substrate

Table 1 shows some of the more important vinasse components followed separately in the presence of *Rhodobacter sphaeroides* and *Clostridium butyricum* as well as of mixed cultures during the fermentation processes. Some of the main vinasse components such as tartaric acid, lactic acid, malic acid and citric acid were subjected to analysis. The residual sugars were determined as reducing agents. *Rhodobacter sphaeroides* showed intense utilization of malic and lactic acids, and partial utilization of tartaric and citric acids. This bacterium was also found to use residual sugars relatively well. *Clostridium butyricum* was characterized by intense utilization of residual sugars as well as by consumption of some of the acids such as lactic and malic acids.

Table 1. Components content of initial vinasse and their residual concentrations at the end of different fermentation processes. In parentheses – the percentage molar consumption of a certain substrate; reducing substances are presented as glucose.

	Tartaric acid (g·l ⁻¹)	Lactic acid (g·l ⁻¹)	Malic acid (g·l ⁻¹)	Citric acid (g·l ⁻¹)	Reducing subst. (%)
Vinasse	1.77	0.077	0.893	0.168	5.5
<i>Rhodobacter sphaeroides</i>	1.578 (10.8%)	0.017 (77.9%)	0.103 (85.5%)	0.146 (13.1%)	1.3 (76%)
<i>Clostridium butyricum</i>	1.7 (4%)	0.031 (59.7%)	0.091 (90.8%)	0.16 (4.8%)	1.1 (80%)
<i>Rhodobacter</i> + <i>Clostridium</i>	0.74 (41.8%)	0.004 (94.8%)	0.017 (98.1%)	0.142 (15.4%)	0.5 (90.9%)

The experiment with a mixture of the two bacteria revealed co-operative assimilation of almost all components in the following sequence: malic acid > lactic acid > residual sugars > tartaric acid > citric acid

Taking into account the fact that *Rhodobacter* and *Clostridium* exist in nature as cooperative population in various kinds of habitats both in water basins and in soil [11] we assumed the probability for them to participate simultaneously in the fermentation processes, utilizing the components of the substrates used and showing mutual tolerance. On the one hand, our studies showed that waste

wine-vinasse was a suitable substrate for hydrogen production in the presence of both *Rhodobacter sphaeroides* and *Clostridium butyricum*, and on the other, organizing a fermentation process with the simultaneous participation of the two organisms, resulted in accelerated and increased hydrogen yield – 65.41 mmol/l vinasse in comparison with separated participation of *Rhodobacter* – 27.41 mmol/l vinasse and *Clostridium* – 25.49 mmol/l vinasse, respectively.

As it is known anoxygenic photosynthetic bacteria as *Rhodobacter sphaeroides* is photoheterotrophs that can grow anaerobically utilizing sunlight and short chain organic acids as substrate. Photosynthetic bacteria utilizing the enzyme nitrogenase, which catalyze to conversion of molecular nitrogen to ammonia as well as evolution of hydrogen according to the Eqn. (1):

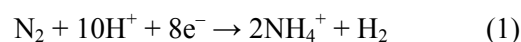

In the absence of N₂ gas the enzyme acts as ATP-depending hydrogenase and simply reduce protons to generate H₂ [12].

On the other hand dark anaerobic fermentative bacteria like *Clostridium butyricum* utilize carbohydrate substrate and H₂ is one of the end products of their metabolism according to the Eqn. (2):

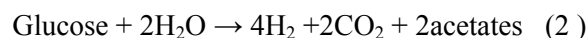

Depending of bacterial species and organic nutrients the fermentation results in generation of small organic acids as malate, lactate, acetate etc. [13, 14]

Based on analysis of the substrate components in our experiments, it may be assumed that they are not assimilated as a simple sum but, more probably, as a result of a cooperative process. Probably, *Rhodobacter sphaeroides* assimilates small organic acids in the substrate-vinasse as well as the metabolite products of *Clostridium butyricum*. The consumption of tartaric acid is of interest. Its assimilation by *Clostridium butyricum* is weak and that by *Rhodobacter sphaeroides*, medium. In the simultaneous presence of the two bacteria, however, drastic exhaustion of this acid is observed. This maybe due to its transformation into a metabolite which is assimilated quickly. The results obtained also showed that both anaerobic fermentations runs together and the light does not disturbs *C. butyricum* fermentation.

In an industrial scheme, the single hydrogen bioreactor with both bacteria can be placed in the same enterprise producing brandy and the illumination could be realized by sun.

CONCLUSION

The main advantages of the present investigation are:

- realization of a fermentation process yielding hydrogen with the use of the simultaneous effect of *Rhodobacter sphaeroidis* and *Clostridium butyricum* on waste vinasse substrate in a single bioreactor, leading to a quick and enhanced hydrogen production as compared to processes with the two bacteria used separately;
- simultaneous utilization of the substrate and the metabolite products by the microorganisms demonstrated the mutual tolerance between them;
- utilization of waste vinasse substrate for the production of hydrogen would be a significant ecological energy resource for wine processing enterprises.

Acknowledgements The authors are much obliged to Milena Ivanova and Tshvetan Tshvetkov diploma students at the Department of Biotechnology for their skilful assistance in carrying out the present investigations.

REFERENCES

1. S. Dunn, *Int. J. Hydrogen Energy*, **27**, 235 (2002).
2. D. Levin, L. Pitt, M. Love, *Int. J. Hydrogen Energy*, **29**, 173 (2004).
3. H. Zhang, M. A. Bruns, B. E. Logan, *Water Res.*, **40**, 728 (2006).
4. Y. Haruhiko, T. Tadafumi, H. Jun, H. Sachio, T. Yoshiyuki, *Biotechnol. Lett.*, **20**, 143 (1998).
5. M. Sunita, Ch. K. Mitra, *J. Biosci.*, **18**, 155 (1993).
6. H. Koku, I. Eroglu, U. Gunduz, M. Vucel, L. Turker, *Int. J. Hydrogen Energy*, **28**, 381 (2003).
7. N. Kaushik, A. Kumar, D. Das, *Appl. Microbiol. Biotechnol.*, **68**, 533 (2005).
8. A. Melis, M. R. Melinski, *Int. J. Hydrogen Energy*, **31**, 1563 (2006).
9. R. K. Clyton, *Biochim. Biophys. Acta*, **37**, 503 (1960).
10. G. C. Miller, *J. Assoc. Offic. Anal. Chemists*, **31**, 420 (1959).
11. R. Osinga, E. Armstrong, J. G. Burgess, F. Hoffmann, J. Reitner, G. Schumann-Kindel, *Hydrobiologia*, **461**, 55 (2001).
12. P. W. Ludden, G. P. Roberts, in: *Anoxygenic Photosynthetic Bacteria*, R. E. Blankenship, M. T. Madigan, C. E. Bauer, (Eds.), Kluwer Academic Publishers; Dordrecht, 1995, p. 929-47.
13. O. R. Zaborsky in: *Biohydrogen*, O. R. Zaborsky, J. R. Benemann, T. Matsunaga, J. Miyake, A. S. Pietro, (Eds.), Plenum Press, New York, 1998, p. 552.
14. K. Nath, D. Das, *Appl. Microbiol. Biotechnol.*; **65**, 520 (2004).

УСКОРЯВАНЕ И ПОВИШАВАНЕ НА ПРОДУКЦИЯТА НА ВОДОРОД С ЕДНОВРЕМЕННА ФЕРМЕНТАЦИЯТА НА *Clostridium butyricum* И *Rhodobacter Sphaeroides* ВЪРХУ СУБСТРАТ ОТ ВИНЕНА ВИНАСА

М. Кръстева^{1*}, И. Лалов¹, В. Бешков²

¹ Катедра „Биотехнология“, Химикотехнологичен и металургичен университет, бул. „Кл. Охридски“ № 8, 1756 София

² Институт по инженерна химия, Българска академия на науките, ул. „Акад. Г. Бончев“, Блок 103, 1113 София

Постъпила на 9 февруари 2009 г.; Преработена на 12 август 2009 г.

(Резюме)

Ферментационен процес за получаване на водород беше организиран като резултат от едновременния ефект на *Rhodobacter sphaeroides* и *Clostridium butyricum* в единичен реактор с осветяване и използване на винена винаса като субстрат. Кинетиката на кооперативния процес показва бърза и повишена продукция на водород с добив от 65.41 mmol/l винаса със смесената култура, в сравнение с процесите, където бактериите се използват поотделно и показват добиви от 27.41 и 25.49 mmol/l винаса, съответно за *Rhodobacter* и *Clostridium*. Експериментът със сместа от двете бактерии, показва кооперативно асимилиране на почти всичките изследвани компоненти в следния ред: ябълчена киселина > млечна киселина > остатъчни захари > винена киселина > лимонена киселина. Използването на винаса като субстрат за продукция на водород би представлявало значителен екологичен енергиен ресурс за предприятията, които произвеждат винено бренди, заедно с оползотворяването на отпадъка винаса.