

Phenol adsorption on activated carbons with different structure and surface properties

B. Petrova¹, T. Budinova^{1,*}, B. Tsyntsarski¹, N. Petrov¹, G. Bardarska², C. Ania³, J. Parra³

¹ Institute of Organic Chemistry, Bulgarian Academy of Sciences, Acad. G. Bonchev St., Block 9, 1113 Sofia, Bulgaria

² Institute of Economics, Bulgarian Academy of Sciences, 3 Aksakov St., 1040 Sofia, Bulgaria

³ Instituto Nacional del Carbon, CSIC, Apartado 73, 33080, Oviedo, Spain

Received July 15, 2009; Revised January 14, 2010

The adsorption of phenol from aqueous solution on activated carbons, produced from agricultural wastes, was studied. Production of carbon adsorbents from agricultural wastes (apricot stones, cob-corn and bean pods) for water treatment is investigated in the paper. Activated carbons (AC) are prepared by pyrolysis of biomass materials in a flow of steam. It is established that the activated carbon obtained by pyrolysis of apricot stones in the presence of water vapour shows the highest adsorption capacity – 172 mg/g. The results from the investigation show that the determining factors for the adsorption of phenol are the porosity parameters.

Key words: agricultural wastes, activated carbon, adsorption, phenol.

INTRODUCTION

Industrial activity is responsible for generating a large volume of organic compounds, which are often difficult or sometimes impossible to remove by conventional biological treatment processes [1]. Phenol is one of the most common organic water pollutants. Phenol and substituted phenols are toxic organic pollutants, usually present in industrial waste waters, especially these from oil refineries, coal conversion plants, pharmaceuticals, *etc.*, and as a class of organics they are similar in structure to the more common herbicides and insecticides, which can explain the fact that they are resistant to biodegradation. In the presence of chlorine in drinking water, phenols form chlorophenols, that have a medicinal taste, which is quite objectionable. Phenol compounds are No 11 in the list of 126 chemicals, which have been acknowledged as priority pollutants by United Environmental Agency [2, 3]. The effective removal of these pollutants from wastewater is a problem of great importance and interest for the society worldwide. There are many methods such as catalytic and photocatalytic oxidation [4, 5], ozonation [6], nanofiltration [7], chlorination [8], adsorption [9, 10], but among them the most widely used method is adsorption onto the surface of activated carbon [10].

Porous carbons have been widely applied in liquid-phase adsorption, separation and purification processes. The high cost of commercial activated carbon has stimulated interest in the examination of the feasibility of using cheaper raw materials for its

production. Substitute materials tested include different sources of biomass (wood material, agricultural by-products, residual polymer materials, residual materials from coal conversion, *etc.* [11–15].

The typical activated carbon particles, whether in a powdered or granular form have porous structure consisting of a network of interconnected macropores, mesopores, and micropores which provide good adsorption capacity towards organic molecules due to the high surface area of the activated carbon. The surface chemistry of the activated carbon and its chemical characteristics such as nature, polarity and solubility of surface ions and functional groups determine the nature of bonding between molecules of adsorbate and activated carbon.

In this paper we will focus on investigating and comparing of the adsorptive properties towards phenol of three different samples of activated carbons, obtained by pyrolysis in the presence of water vapour from some wide-spread agricultural by-products (apricot stones, cob-corn and bean pods), and their application for removal of phenol from aqueous solution.

MATERIALS AND METHODS

Preparation of activated carbons

Different agricultural by-products (apricot stones, cob-corn and bean pods) were used as raw materials for preparation of activated carbons. The samples were pyrolysed in a stream of water vapour in the equipment, shown in Figure 1.

* To whom all correspondence should be sent:
E-mail: goriva@orgchm.bas.bg

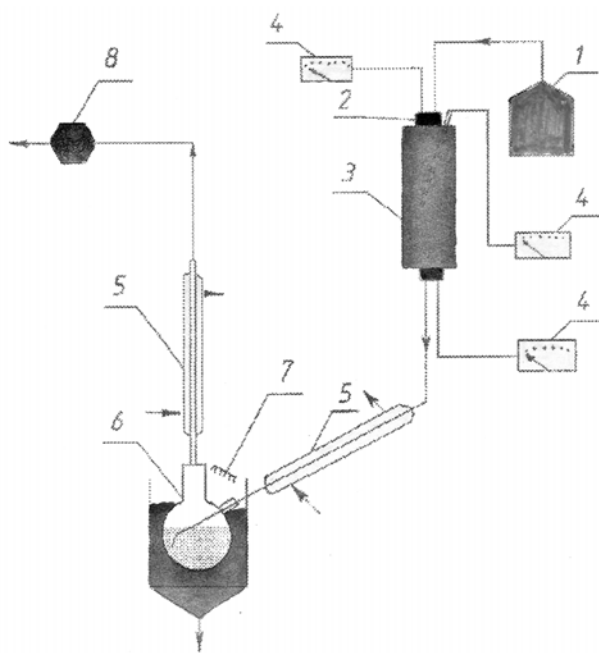

Fig. 1. Equipment for production of carbon adsorbents: 1 - generator of water vapour; 2 - reactor; 3 - furnace; 4 - thermocouple; 5 - cooler; 6 - collector for liquid products; 7 - water cooling.

According to the specific characteristics of the initial raw materials the preparation of the activated carbons from apricot stones, cob-corn and bean pods, is performed in different ways. The details of the procedures for producing activated carbons from these agricultural wastes are as follows:

The activated carbon from apricot stones has been prepared by one-step pyrolysis of crashed apricot stones in the presence of water vapour. In this method carbonization and activation were performed simultaneously in contrast with the two-stage process of carbonization and consecutive activation. Apricot stones (100 g) were heated in our laboratory installation (Fig. 1) in a flow of water vapour (120 ml/min) with a heating rate of 15°C/min up to a final carbonization temperature of 800°C. The duration of treatment at the final temperature is 1 h. After the treatment the sample is left to cool down in flow of water vapor. The obtained activated carbon is denoted as Carbon A.

Bean pods and cob corn were carbonized and after that activated with water vapor because otherwise the initial waste materials would hinder the passing of the activating agent (water vapor) through the sample. Bean pods and cob-corn wastes were carbonized as 50 g of the raw material (fraction 1–5 mm) by heating in the laboratory installation (Fig. 1) with heating rate of 60°C·min⁻¹ up to a carbonization temperature of 600°C. The sample was maintained at the final temperature for 10 min,

and then cooled down to ambient temperature in flow of water vapor. After that the solid product was activated with water vapor at 700°C for 1 hour. These activated carbons are denoted as Carbon B – from cob corn and Carbon C – from bean pods.

The volatile products were carried by water vapor into receiver where they were condensed.

Pore structure analysis

The textural characterization was carried out by measuring N₂ adsorption isotherm at –196°C and applying an ASAP 2010 M instrument (Micromeritics Corp., Norcross GA). Before the experiments the sample (ca. 0.3 g) was outgassed at 150°C under vacuum for ca. 24 h. Different model methods (i.e. BET and Dubinin-Radushkevich) were applied to the N₂ adsorption isotherm in order to calculate the specific surface area and micropore volume [16].

Oxygen-containing functional groups

The amount of oxygen-containing functional groups with increasing acidity was determined by Boehm's method of titration with basic solutions of different base strengths (NaHCO₃, Na₂CO₃, NaOH, C₂H₅ONa): carboxylic groups (analyzed with titration of NaHCO₃), carboxylic groups in lactone like binding structures (determined from the difference between the consumption of NaHCO₃ and Na₂CO₃), phenolic hydroxyl groups (determined from the difference between NaOH and Na₂CO₃ consumption) and carbonyl groups (determined from the difference between NaOEt and NaOH consumption) as well as the total amount of basic groups, determined by titration of HCl. For this purpose the samples were agitated for at least 16 hours with 0.05 N solutions of the four bases. The amount of Na⁺ ions remaining in the solution was determined by adding an excess of standard HCl water solution and back-titration [17]. The basic groups content of the samples was determined with 0.05 N HCl [18].

pH Measurements

The pH values of the obtained carbons were measured according to the following procedure: exactly 4.0 g of carbon was weighted into a 250 ml beaker, and 100 ml of bi-distilled water (pH= 5.70) was added. The beaker was covered with a watch glass, and the mixture was boiled for 5 min. The suspension was set aside, and the supernatant liquid was poured off as hot as possible but not below 60°C. The decanted portion was cooled down to ambient temperature, and its pH value was measured to the nearest 0.1 pH unit.

Table 1. Proximate and elemental analysis of the raw precursors and the activated carbons, produced by steam pyrolysis.

No.	Raw material/ Activated carbon	Proximate analysis, %			Ultimate analysis, %				
		Ash	Volatiles	C	H	N	S	O	
1	Apricot stones/	0.20/	80.60/	51.50/	6.30/	0.20/	0.10/	41.90/	
	Activated carbon A	2.01	3.70	89.50	2.40	0.90	0.80	6.40	
2	Cob-corn/	5.00/	84.49/	45.50/	6.34/	0.62/	0.06/	47.48/	
	Activated carbon B	15.10	20.80	62.90	3.50	0.54	0.05	33.01	
3	Bean pods/	6.09/	80.07/	43.25/	5.98/	0.92/	0.11/	49.74/	
	Activated carbon C	22.80	30.26	60.25	3.90	0.73	0.16	34.96	

Table 3. Porosity characteristics and adsorption capacities of the activated carbons, produced from apricot stones, cob-corn and bean pods.

No.	Activated carbon, produced from:	Iodine number, mg/g	Surface area-BET m ² /g	Pore volume, cm ³ /g			
				Micro	Meso	Macro	Total
1	A – apricot stones	900	960	0.760	0.100	0.040	0.91
2	B – cob-corn	650	500	0.270	0.080	0.050	0.40
3	C – bean pods	500	258	0.107	0.070	0.033	0.21

Adsorption Measurements

All adsorption experiments were carried out by using an adsorbent sieve fraction with particles 0.2 mm in size. The adsorption capacity of the adsorbents towards phenol was investigated by using aqueous solution of phenol. Phenol was obtained from Merck (99% purity). The phenol solutions were prepared in the concentration range of 100–300 mg/l. The principle of our experiments was as follows: 100 mg of activated carbons were mixed with 50 ml of phenol solution with desired concentration in 100 ml capacity stopped flasks. The stopped flasks containing the adsorbent and the adsorbate were agitated for predetermined time intervals at room temperature on a mechanical shaker. At the end of agitation, the suspension was filtered through microporous filter paper (hydrochloric acid filter and hydrofluoric extraction, FILTRAK 390). The suspensions were shaken to reach stable equilibrium (2 hours). The phenol concentrations were determined spectrophotometrically at maximum absorbance wavelength $\lambda = 269$ nm using Pfarlo 300 UV spectrophotometer.

RESULTS AND DISCUSSION

Chemical composition

The analysis of the structure and the composition of the agricultural wastes is very important because it allows to obtain preliminary results on their application as a source for yielding of liquid and solid products with definite properties, and to select the appropriate method of their treatment as well. Chemical composition data of the raw precursors and the produced activated carbons are shown in Table 1.

Activated carbon obtained by one step method of pyrolysis in the presence of water vapour of apricot stones possesses a higher content of carbon, lower content of oxygen and ash, which are desirable features for activated carbon production. Comparatively, carbons from bean pods and cob-corn have higher ash content, higher amount of oxygen and lower content of carbon.

Surface oxygen groups

The functional groups on the surface of activated carbons have strong effect on the adsorption properties. Table 2 compares the amounts of different oxygen groups on the surface of activated carbons.

Table 2. Quantification of oxygen groups on activated carbons surface (meq/g).

Activated carbon	pH	Acidic surface functional groups				Basic groups
		Carboxyl	Lactonic	Hydroxyl	Carbonyl	
A	10.7	0.13	0.19	0.09	0.98	1.24
B	9.2	BDL*	BDL	0.25	2.95	2.60
C	10.7	BDL	BDL	0.21	1.31	7.40

* BDL – below detection limit.

The data in Table 2 show the influence of the raw materials on the character of the oxygen-containing groups. It is determined that various oxygen-containing groups with different chemical properties are present on the activated carbon surface. The surface of all three samples of activated carbons has basic nature. Acidic groups (carboxylic and lactone-like binding structures) are detected only on the surface of activated carbon prepared from apricot stones, whereas phenolic hydroxyl and carbonyl groups are present in all three carbon samples. The amount of basic groups is nearly six times higher for carbon C in comparison with Carbon A, which is in a good agreement with the

measured pH values. Such basic activity could be due to the presence of oxygen containing groups of basic nature or related to the species in the inorganic matter of this carbon. The determined amount of carboxylic groups in lactonic structures in the activated carbon from apricot stones is probably due to the method of activation, namely simultaneous performing of the processes of carbonization and activation.

Textural characteristics

The porosity has a strong effect on the adsorption properties of the activated carbons. Table 3 compares the porosity characteristics of activated carbons obtained from apricot stones, cob-corn and bean-pods. The samples obtained from apricot stones have the largest total volume of the pores, with significant prevalence of the micropores. The samples from bean pods and cob-corn have considerably lower surface area and volume of micropores. We have reported that the composition of agricultural by-products has a strong influence on the final porosity and chemical features of solid product obtained from pyrolysis and activation. It was found that the low ratios of lignine:cellulose favor the development of predominantly microporous materials [19].

Activated carbon adsorption of phenol from water solution

Effect of contact time. The distribution of adsorbed substance between activated carbon and adsorbate solution for the system at equilibrium is of importance for determining the maximum adsorption capacity of activated carbon for phenol. Figure 2 shows the effect of the time interval of treatment on the removal of phenol by activated carbon obtained from apricot stones. Phenol adsorption increases sharply for a short period of time and then shows a gradual increase when the equilibrium is approached. This behaviour can be attributed to the relative decrease in the number of available sites on the carbon surface as the process advances.

The plots show that the amount of phenol adsorbed on the adsorbents (mg/g) varies in single smooth and continuous curve, leading to saturation and thus suggesting the possibility of the formation of monolayer coverage of phenol on the surface of the adsorbent.

The data indicate that the removal of phenol attains equilibrium in 60 minutes for all initial concentrations of the phenol solution. The kinetic curves of the removal of phenol versus time of treatment for carbon B and C show the same dependence.

Adsorption isotherm. Adsorption is a well known equilibrium separation process for treatment of water containing organics. The adsorption isotherm of phenol on carbon A is presented in Figure 3. The amount of phenol adsorbed at equilibrium per carbon mass unit for all concentrations (100–300 mg/l) is presented as a function of the equilibrium phenol concentration. The adsorption isotherm in Figure 3 could be assigned to the L(2) class according to the Giles classification [20]. L-type isotherms correspond to the completion of monolayers in experimental concentration ranges.

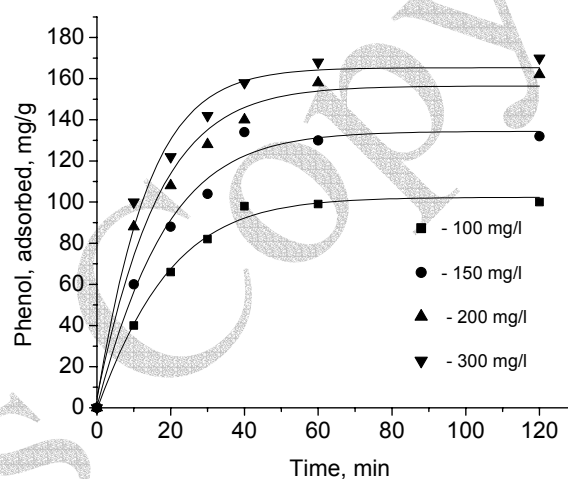

Fig. 2. Effect of treatment time and initial concentrations of phenol on the adsorption on Carbon A. Conditions: carbon concentration 100 mg/50 ml, Phenol concentrations: (■) 100 mg/l, (●) 150 mg/l, (▲) 200 mg/l, and (▼) 300 mg/l.

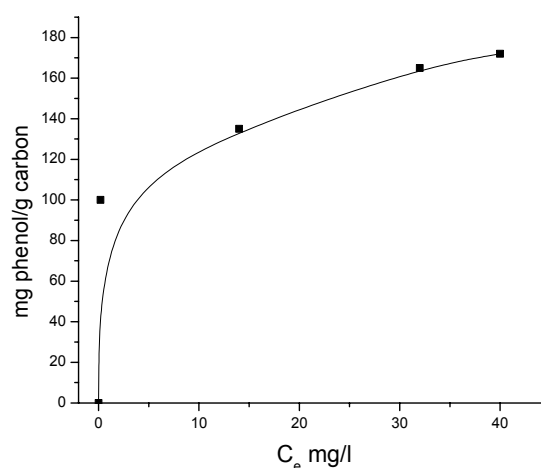

Fig. 3. Phenol isotherm on activated carbon A. Phenol concentrations 100–300 mg/l; treatment time, 120 min, carbon concentration 100 mg/50 ml.

The linear form of the Langmuir's equation [16] is applied to calculate the adsorption capacity of activated carbons:

$$q_{eq} = Q_0 b C_{eq} / (1 + b C_{eq}) \quad (1)$$

where C_{eq} is residual (equilibrium) pollutant concentration (mg/l); q_{eq} – amount of pollutant bound to the adsorbent (mg/g); Q_0 – maximum amount of the pollutant per unit weight of adsorbent, mg/g; b – constant related to the affinity of adsorption sites (l/mg); Q_0 represents the practical limiting adsorption capacity when the surface is completely covered with pollutant molecules.

The Langmuir plots for adsorption of phenol on carbons A, B and C are presented in Figure 4.

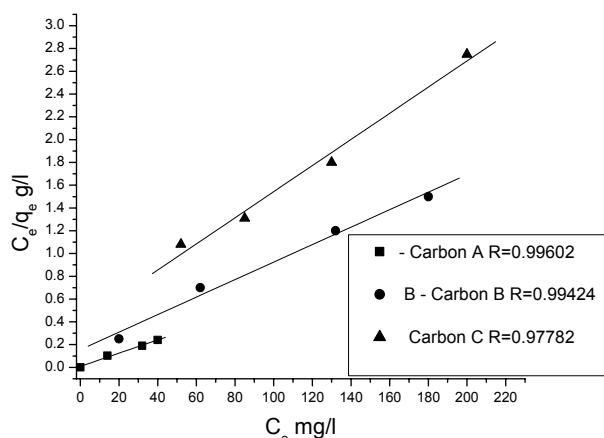

Fig. 4. Langmuir plots for adsorption of phenol on different types of activated carbons: ■ - A; ● - B; ▲ - C.

The linear plot of C_e/q_e versus C_e shows that adsorption obeys the Langmuir's isotherm model (Figure 4). The calculated values of Q_0 and b are presented in Table 4.

Table 4. Data for phenol adsorption obtained from Langmuir's plots.

Type of activated carbon	Q_0 , mg/g	b , l/mg	R^*
A	172	0.07330	0.99602
B	130	0.00770	0.99424
C	89	0.40567	0.98724

R^* -correlation coefficient.

All these isotherms are fitted to the experimental adsorption data. Correlation coefficients, calculated for these isotherms by using linear regression procedures, show that the Langmuir's isotherms fit excellent to the experimental data. This confirms too that the removal of phenol from solution on the prepared carbons can be described by the Langmuir's theory, which states that the adsorption proceeds *via* a monolayer formation, displaying the typical L-shape according to Giles classification too (Fig. 2).

The adsorption capacity of 172 mg/g for phenol on activated carbon, produced after pyrolysis of apricot stones in water vapour, is higher than those from bean pods and cob-corn. The activated carbon A, possesses considerable high specific surface area

(BET), and significant total pore and micropore volumes. The activated carbon C, which possesses lower specific surface area, shows nearly 52% lower adsorption capacity than activated carbon A.

The studies on the mechanism of phenol retention on activated carbons have shown that it is a complex one and that adsorption may take place on different active sites and it strongly depends on the pore texture, surface chemistry and the mineral matter content. The adsorption capacity of carbon materials is not related in a simple form with their surface area and porosity. The adsorption capacity depends on the access of the organic molecules to the inner surface of the adsorbents, which depends on their size. Thus, under appropriate experimental conditions, small molecules such as phenol, can access micropores and for this reason the activated carbon from apricot stones with higher content of micropores has the highest value of adsorption capacity towards phenol. It has to be mentioned too that independently of the lower content of micropores, Carbon B and Carbon C show high adsorption capacity, which is obviously due to the surface chemistry (higher content of oxygen group-carbonyl and basic groups in comparison with Carbon A).

Mattson and co-workers suggested that aromatic compounds are adsorbed on carbons by a donor-acceptor complex mechanism, with the carbonyl oxygen of the carbon surface acting as an electron donor, and the aromatic ring of the adsorbate acting as acceptor [26]. This is valid especially for carbon B, which has 3 times higher content of carbonyl groups and 3 times lower content of micropores in comparison with Carbon A, whereas the adsorption capacity is slightly lower – 130 mg/g.

CONCLUSIONS

Activated carbons, produced from agricultural wastes as apricot stones, bean pods, cob-corn after steam pyrolysis, are suitable for treatment of phenol polluted water. The most active is activated carbon from apricot stones, followed by activated carbon from cob-corn and bean pods. The most substantial factors with big influence on phenol adsorption are the surface area and porosity characteristics. The obtained adsorption capacity of 172 mg phenol by 1 g activated carbon shows that the activated carbon from apricot stones is highly promising. Using the agriculture wastes for producing activated carbon, needed for water treatment, is an ecologically friendly approach with socio-economic effect.

Acknowledgements: The authors acknowledge financial support for this work by MEYS-NFSI, Bulgaria (grant 02-222/17.12.2008).

REFERENCES

1. F. Caturla, M. Martin-Martines, M. Molina-Sabio, F. Rodriguez-Reinoso, R. Torregrosa, *J. Coll. Interface Sci.* **124**, 528 (1998).
2. EU Water Framework Directive, Directive 2000/60/EC, Ogg. J., L 327, 22 December 2000.
3. Environmental quality standards for priority substances and certain other pollutants, Directive 2008/105/EC, 16 December 2008.
4. F. Larachi, I. Ihuta, K. Belkacemi, *Catal. Today*, **64**, 309 (2001)
5. Md. Ahmaruzzaman, *Adv. Coll. Interface Sci.*, **14**, 48 (2008).
6. C. Cooper, R. Burch, *Water Res.*, **33**, 3695 (1999).
7. J. M. Arzuada, M. J. Lopez-Munoz, J. Aguado, A. Sotto, *Desalination*, **221**, 253 (2008).
8. V. V. Goncharuk, Ecological Aspects of Modern Technologies of Protecting Water Medium, Kiev, Naukova Dumka, 2005, p. 400 (in Russian).
9. H. B. Crauford, G. Cline, Water Treatment Plant Design, Kh. A. Halhouli, N. A. Darwish, N. M. Ahlhoon (Eds.), American Society of Civil Engineers, American Water Works Association, Mc Graw Hill, New York, (1990) p. 457.
10. L. R. Radovic, C. Moreno-Castilla, J. Rivera-Utrilla, in: Chemistry and Physics of Carbon, v. 27, L. R. Radovic (Ed.), Marcel Dekker, New York, 2001, p. 227–405.
11. E. D. Larsen, Proc. 2nd Olle Lindström Symposium on Renewable Energy-Bioenergy, 9–11 June, 1999, Royal Institute of Technology, Stockholm, Sweden, 1999, p. 1–3.
12. T. Budinova, E. Ekinci, F. Yardim, A. Grimm, E. Bjornbom, V. Minkova, M. Goranova, *Fuel Proc. Technol.*, **87**, 899 (2006).
13. N. Petrov, T. Budinova, M. Razvigorova, E. Ekinci, F. Yardim, V. Minkova, *Carbon*, **38**, 2069 (2002).
14. N. Petrov, T. Budinova, M. Razvigorova, J. Parra, P. Galiatsatou, *Biomass and Bioenergy*, **32**, 1303 (2008).
15. F. Rodriguez-Reinoso, M. Molina-Sabio, M. T. Gonzales, *Carbon*, **33**, 15 (1995).
16. S. J. Gregg, K. S. W. Sing, in: Adsorption, Surface Area and Porosity; Academic Press, London, 1982, p. 1.
17. H. P. Boehm, in: *Adv. Catal. Rel. Subj.*, vol. 16, D. D. Eley, H. Pines, P. B. Weisz (Eds.), Academic Press, New York, 1966, pp. 179–274.
18. E. Papier, S. Li, J. B. Donnet, *Carbon*, **25**, 243 (1987).
19. D. Savova, E. Apak, E. Ekinci, F. Yardim, N. Petrov, T. Budinova, M. Razvigorova, V. Minkova, *Biomass and Bioenergy*, **21** 1333 (2001).
20. C. H. Giles, T. H. MacEwan, S. N. Nakhwa, D. Smith, *J. Chem. Soc.*, 3973 (1960).
21. K. Laszlo, E. Tombasz, C. Novak, *Colloids Surf. A: Physicochem. Eng. Aspects*, **306**, 95 (2007).
22. A. P. Terzyk, *J. Colloid Interface Sci.*, **2689**, 310 (2003).
23. K. F. Loughin, M. M. Hassan, E. O. Ekhtor, G. F. Nakhia, Proc. 5th Int. Conf. Fundamentals of Adsorption, Kluwer, Boston, 1996, pp. 537–544.
24. T. M. Grant, C. J. King, *Ind. Eng. Chem. Res.*, **29**, 264 (1990).
25. I. I. Salame, T. J. Badosz, *J. Coll. Interface Sci.*, **264**, 307 (2003).
26. J. S. Mattson, Jr., H. B. Mark, M. D. Malbin, Jr., W. J. Weber, J. C. Crittenden, *J. Colloid Interface Sci.*, **31**, 116 (1969).

АДСОРБЦИЯ НА ФЕНОЛ ВЪРХУ АКТИВНИ ВЪГЛЕНИ С РАЗЛИЧНИ СТРУКТУРНИ И ПОВЪРХНОСТНИ ХАРАКТЕРИСТИКИ

Б. Петрова¹, Т. Будинова^{1,*}, Б. Цинцарски¹, Н. Петров¹, Г. Бардарска², К. Аня³, Х. Пара³

¹ Институт по органична химия с център по фитохимия, Българска академия на науките, ул. „Акад. Г. Бончев“, блок 9, 1113 София

² Икономически институт, Българска академия на науките, ул. „Аксаков“ № 3, 1040 София

³ Институт по въглерод, Апатадо 73, 33080 Овиедо, Испания

Постъпила на 15 юли 2009 г.; Преработена на 14 януари 2010 г.

(Резюме)

Изследвана е адсорбцията на фенол върху активни въглени, получени от отпадни селскостопански продукти (кайсиеви костилки, бобени шушулки и кочани от царевица). Активните въглени са получени чрез пиролиз в присъствие на водна пара. Процесът пиролиз в присъствие на водна пара дава възможност да се получат течни и газообразни продукти и високоефективни активни въглени. Резултатите показваха, че най-висока адсорбционна способност спрямо фенол (172 mg/g) показва активния въглен, получен при процеса пиролиз на кайсиеви костилки.