

## 3D modelling of heat and mass transfer processes during the combustion of liquid fuel

A. Askarova<sup>1</sup>, S. Bolegenova<sup>2\*</sup>, N. Mazhrenova<sup>2</sup>, R. Manatbayev<sup>2</sup>, Sh. Ospanova<sup>1</sup>, Symbat Bolegenova<sup>2</sup>, I. Berezovskaya<sup>1</sup>, V. Maximov<sup>1</sup>, A. Nugymanova<sup>2</sup>, Zh. Shortanbayeva<sup>2</sup>

<sup>1</sup> *SRI of Experimental and theoretical physic, Al-Farabi Kazakh National University, Almaty, Kazakhstan*

<sup>2</sup> *Faculty of Physics and Technology, Al-Farabi Kazakh National University, Almaty, Kazakhstan*

In this article numerical study of the processes of atomization and combustion of two kinds of liquid fuel by using the statistical model of breakup and dispersion of the drops was conducted. The octane and dodecane were used as liquid fuels in the researches. There was also constructed the model of the combustion chamber in a cylinder form. During the numerical simulation has been determined optimum combustion mode for two types of liquid fuel. The initial temperature in the combustion chamber was varied from 700 to 1500 K. It was shown that for the two types of liquid fuel the oxidant's optimal initial temperature in the combustion chamber is 900 K. It was determined the optimum value of the initial temperature in the combustion chamber. Computational experiments on research of the distribution of the maximum temperature, the concentration of the combustion products and the dispersion of liquid particles were performed.

**Keywords:** liquid fuel, numerical modeling, octane, dodecane, combustion, statistical model, initial temperature

### INTRODUCTION

At the present time, despite the ongoing efforts in the development and use of renewable energy, 85% of all energy consumed in the world are received from the combustion of fossil fuels. Statistics show that 39% of the total energy consumption are accounted for the liquid types of fuels' combustion and 97% of this total energy is used in the transport sector [1]. While still in the world widely liquid fuels are used as a primary energy source, it is paramount the increasing the efficiency of their combustion and thereby minimizing the impact on the environment.

The development of energy conversion systems with high efficiency and low emissions plays a major role in reducing of greenhouse gas emissions to the atmosphere. Necessity of a detailed study of physical and chemical processes occurring during combustion of liquid types of fuels is determined by increasing requirements for effectiveness of the various technical devices, necessity of accurately determine the moment of ignition and due to modern environmental requirements. On the other hand the results of basic research of physical and chemical processes of combustion allow to find effective modes of various technical devices, including internal combustion engines [2].

In this regard computer simulation of the physical and chemical processes of breakup, dispersion, vaporization and combustion of liquid

fuel droplets at different initial conditions in internal combustion engines is relevant. The combustion of liquid fuels has a number of specific features, due to chemical reactions in a dynamic and thermal interaction between of the reagents and the intensive mass transfer during phase transitions, as well as the dependence of the process parameters as the thermodynamic state of the system and of its structural characteristics. As the investigation of combustion is impossible without a detailed study, that comes to the fore the problem of the fundamental laws of processes of heat and mass transfer research during the combustion of various types of fuels. This article is devoted to the numerical simulation of the processes of atomization and combustion of two kinds of liquid fuel.

Atomization of the fuel jet has wide application in many fuel supply systems, as well as in combustion chambers of the modern aircraft engines. This type of flow in a radial cross-flow enhances fuel atomization characteristics which generated injection and vaporization and is used in premix and evaporative fuel-air mixture chambers. When liquid fuel is sprayed from the gas turbine engine nozzle droplets sizes may reach several microns, while the sizes of the fuel channels exceeds by several orders.

With the development of modern science of jet technology, many researchers have begun to focus on thermal and chemical processes occurring inside the engines of missile and aviation technology. So M. Gorokhovski in his work [3] has developed a

\* To whom all correspondence should be sent:  
saltanat.bolegenova@kaznu.kz

new subgrid stochastic model for liquid particles breakup at high turbulence. The developed model describes the decay of elementary particles in a space where the liquid spreads through the relaxation time in the distribution of the droplet radii. This model was implemented in the KIVA-II software package together with the Lagrangian particle trajectory tracking model.

In [4] M. Gorokhovski and V. Savel'ev in the framework of Kolmogorov decay theory for large numbers of Weber studied the decay of liquid droplets. In this paper it was given balance equation for the droplet population distribution radially in the form of the invariant under the group of large-scale transformation. In this work the authors have shown that due to the law of symmetry ultimate solution of this equation is a function of power.

Also in the [4] work the authors used subgrid stochastic model for the study of atomized liquid droplets. Following Kolmogorov concept, considering the collapse of solid particles in the form of a discrete random process, the authors studied the work of spray liquid clumps at a high relative velocity of the moving gas during the uncorrelated breakup events that turn to howl do not depend on the initial droplet size. Also the discrete model of the Kolmogorov's breakup has been modified in the form of the Fokker-Planck differential equation for the probability density function of droplet radii.

In this paper KIVA-II was used as a starting package of computer programs, which was developed by scientists from the Los Alamos National Laboratory (LANL). All the computational experiments were done by using this computer program which are used for the numerical calculation of two- and three-dimensional chemical reactive fluid flows with sprays. The KIVA-II equations and numerical solution procedure are very general and can be applied to laminar or turbulent flows, subsonic or supersonic flows and single phase or dispersed two-phase flows. With this software package is possible to explore the complex processes of ignition, combustion of the fuel and air mixtures, as well as the processes of formation of pollutants released into the atmosphere as a result of the internal combustion engine's work [3-5].

In this paper a computer package KIVA-II software has been optimized to simulate the chemical kinetics of combustion processes in diesel and aircraft engines. This software package has been adapted to the task of the incineration of the liquid fuel in the combustion chamber at high

turbulence. With KIVA-II it was possible to calculate the aerodynamic of the flow, injection mass, oxidant's temperature, pressure, turbulent characteristics, the concentration of combustion products, fuel vapor and other characteristics of the process of liquid fuel combustion across the combustion chamber space.

A statistic particle method is used to calculate evaporating liquid sprays, including the effects of droplet collisions and aerodynamic breakups. The initial and boundary conditions and mesh generation have been written for internal engine calculations.

## MATHEMATICAL MODEL

In this article the Kolmogorov's discrete model has been reproduced in the form of evolution equation for distribution function of the drops' radius. The asymptotic solution of this equation has been applied to simulate the drop breakup alongside with statistical model of spray dynamics [3].

The breakup of parent drops into secondary droplets is viewed as the temporal and spatial evolution of this distribution function around the parent-droplet size according to the Fokker-Planck differential equation [4-5]:

$$\frac{\partial f(x,t)}{\partial t} + \nu(\xi) \frac{\partial f(x,t)}{\partial x} = \frac{1}{2} \nu(\xi^2) \frac{\partial^2 f(x,t)}{\partial x^2}, \quad (1)$$

where  $\nu$  is the breakup frequency (Hz) and  $t$  is the breakup time (ms). Here,  $f(x,t)$  is the distribution function for  $x = \ln(r)$ , and  $r$  is the droplet radius ( $\mu\text{m}$ ).

The value of the breakup frequency and the critical radius of breakup are obtained by the balance between the aerodynamic and surface tension forces. The critical radius of breakup becomes [6]:

$$r_{cr} = \left( \frac{9 We_{cr} \sigma \nu_{lam}}{2 \varepsilon \rho_l} \right)^{1/3}, \quad (2)$$

where  $\nu_{lam}$  is the kinematic viscosity (St),  $\rho_l$  is the liquid density ( $\text{kg/m}^3$ ),  $\varepsilon$  is the viscous dissipation rate,  $We_{cr}$  is the critical Weber number, which is assumed to be on the order of six over a wide range of Ohnesorge numbers:

$$We = \frac{\rho_g (u_g - u_l)^2 D_l}{2\sigma}, \quad (3)$$

where  $u_g$  (m/s) and  $u_l$  (m/s) are the velocities of liquid and gas, respectively,  $D_l$  (cm) is the inlet diameter for the liquid jet.

In the statistical model the discrete particle distribution function is approximated by a discrete particle dispersion [7]:

$$f' = \sum_{p=1}^{NP} N_p \delta(\bar{x} - \bar{x}_p) \delta(\bar{v} - \bar{v}_p) \delta(r - r_p) \delta(T - T_{dp}) \delta(y - y_p) \delta(\dot{y} - \dot{y}_p), \quad (4)$$

where  $p$  is the particle,  $N_p$  - the total number of the particle,  $\bar{x}_p$  - the location of the particle in space,  $\bar{v}_p$  - velocity of the particle (m/s),  $r_p$  - radius of the particle ( $\mu\text{m}$ ),  $\dot{y}_p$  - deviation from a spherical particle shape.

During the dispersion of the particles in a turbulent gas flow fluctuation of the velocity component is a function of the time which changes intermittently after the passage of turbulent correlation time, which in turn is determined by the following relationship [8]:

$$t_{turb} = \min\left(\frac{k}{\varepsilon}, c_{ps} \frac{k^{3/2}}{\varepsilon} \frac{1}{|\bar{u} + \bar{u}' - \bar{v}|}\right), \quad (5)$$

here  $c_{ps}$  is an empirical constant with a value of 0,16432,  $k$  – turbulent kinetic energy,  $\varepsilon$  - its dissipation rate. Therefore  $t_{turb}$  (ms) represents the minimum of an eddy breakup time and a time required by a droplet to traverse or pass through an eddy. The sum of the mean and fluctuating velocity component is the gas velocity which a particle sees during the computation of drag, mass transfer, momentum transfer, oscillations and breakup.

When a particle moves in a turbulent gas stream with a large-scale structures whose dimensions are much greater than the particle diameter, the relative velocity between the particle and the gas flow is determined as follows:

$$\frac{d\bar{v}_p}{dt} = \frac{(\bar{v}_g - \bar{v}_p) |\bar{v}_g - \bar{v}_p|}{\tau_{St}}, \quad (6)$$

where  $\tau_{St} = \frac{\rho_p d_p^2}{18\rho_g \nu_g}$  is the droplet relaxation time

scale (s), where  $d_p$  ( $\mu\text{m}$ ) is the diameter of the droplet.

The majority of currents by the nature have turbulent character, a condition of turbulence strongly influences on such parameters of a current as transfer of an impulse, temperatures and concentration of substances in the mixture during the flow motion. In this chapter, the thesis shows the mathematical model describing the burning of liquid fuels on the basis of the equations of conservation of mass ( $\rho$ ,  $\text{kg}/\text{m}^3$ ), momentum ( $\rho\bar{u}$ ,  $\text{kg}\cdot\text{m}/\text{s}$ ) energy ( $E$ , J) and concentration ( $c$ ,  $\text{kg}/\text{kg}$ ).

$$\frac{\partial\rho}{\partial t} + \text{div}(\rho\bar{u}) = S_{mass}, \quad (7)$$

where  $u$  - the velocity of the fluid (m/s). The source term  $S_{mass}$  is a local change of gas density due to evaporation or condensation.

The conservation equation of an impulse of gas has the following appearance:

$$\rho \frac{\partial\bar{u}}{\partial t} + \rho(\bar{u} \cdot \text{grad})\bar{u} = \text{div}\bar{\xi} + \rho\bar{g} + S_{mom}. \quad (8)$$

$S_{mom} = 0$  for a single-phase flow of gas;  $S_{mom}$  is the local rate of change in momentum in the gas phase due to the movement of droplets for two-phase.

Conservation equation of an internal energy:

$$\rho \frac{\partial E}{\partial t} = \bar{\tau} : \bar{D} - \rho \text{div}\bar{u} - \text{div}\bar{q} + S_{energy}, \quad (9)$$

where  $q$  – the specific heat flux ( $\text{W}/\text{m}^2$ ), it is the Fourier law of heat transfer,  $\bar{\tau} : \bar{D}$  is the rate of increase of the internal energy due to viscous dissipation. Source term  $S_{energy}$  denotes the contribution to the change of an internal energy due to the presence of atomized liquid or solid phase.

The conservation equation of concentration of a component:

$$\frac{\partial(\rho c_m)}{\partial t} = - \frac{\partial(\rho c_m u_i)}{\partial x_i} + \frac{\partial}{\partial x_i} \left( \rho \cdot D_{c_m} \cdot \frac{\partial c_m}{\partial x_i} \right) + S_{mass}, \quad (10)$$

where  $\rho_m$  - a mass density of a component  $m$  ( $\text{kg}/\text{m}^3$ ),  $\rho$  - full mass density ( $\text{kg}/\text{m}^3$ ).

More universal models in engineering calculations of turbulent flows are models with two differential equations. Using in technical flows model with two differential equations is the most

common.  $k - \varepsilon$  is model when two equations for a kinetic energy of turbulence and dissipation rate are solved:

$$\rho \frac{\partial k}{\partial t} + \rho \frac{\partial \bar{u}_j k}{\partial x_j} = \frac{\partial}{\partial x_j} \left[ \left( \mu + \frac{\mu_t}{\sigma_k} \right) \frac{\partial k}{\partial x_j} \right] \frac{\partial \bar{u}_i}{\partial x_j} + G - \frac{2}{3} \rho k \delta_{ij} \frac{\partial \bar{u}_i}{\partial x_j} - \rho \varepsilon \quad (11)$$

$$\rho \frac{\partial \varepsilon}{\partial t} + \rho \frac{\partial \bar{u}_j \varepsilon}{\partial x_j} - \frac{\partial}{\partial x_j} \left[ \left( \mu + \frac{\mu_t}{\sigma_\varepsilon} \right) \frac{\partial \varepsilon}{\partial x_j} \right] = c_{\varepsilon_1} \frac{\varepsilon}{k} G - \left[ \left( \frac{2}{3} c_{\varepsilon_2} - c_{\varepsilon_3} \right) \rho \varepsilon \delta_{ij} \frac{\partial \bar{u}_i}{\partial x_j} \right] - c_{\varepsilon_3} \rho \frac{\varepsilon^2}{k} \quad (12)$$

This is the standard  $k - \varepsilon$  equations. Values  $C_{\varepsilon_1}$ ,  $C_{\varepsilon_2}$ ,  $C_{\varepsilon_3}$ ,  $\sigma_k$ ,  $\sigma_\varepsilon$  are modal constants which are determined from the experiment. Typical values of these constants are commonly used in engineering calculations and are taken from the literature [4-5].

Chemical kinetics of combustion is represented as generalized chemical reactions for the two kinds of fuel - octane and dodecane:

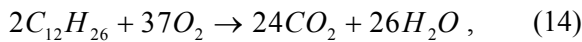

as a result  $CO_2$  and  $H_2O$  combustion products are formed.

Octane is a hydrocarbon and an alkane. Octane has many structural isomers that differ by the amount and location of branching in the carbon chain. One of its isomers isooctane is used as a standard value in fuel octane rating scale. Octane is a part of the gasoline. Kazakhstan oil is characterized by the predominance of normal paraffins, so straight run gasoline of them have low octane numbers. As octane is used as an index of the fuel in the engine to resist the high compression ratio, which is a characteristic of the octane branched chain isomers, especially of them can be identified isooctane. Octane is contained in large amounts in the composition of oil, straight run gasoline (10%) and in a large amount in the synthetic gasoline produced from CO and  $H_2$ . In industry octane was isolated by distillation, and then purified by urea using molecular sieves.

Dodecane is a liquid hydrocarbon from class of alkane, oily liquid from the paraffin series. Dodecane is used in industrial and laboratory

practice as a solvent. It is used for analytical purposes in the study of the composition of oil fractions. Also it is used for the manufacture of olefins and biodegradable detergent component as vaseline oil. In recent years it has begun n-dodecane used as a possible substitute for kerosene fuels, such as Jet-A, S-8, and other conventional aviation fuels. The fuel of the second generation, which is dodecane, ousted n-decane because of its higher molecular mass, it is best to interact with the n-alkanes in the composition of jet fuel.

In this work a model of the combustion chamber in the cylinder form the height of which is 15 cm, 4 cm in diameter has been used. General view of the combustion chamber is shown in Fig.1. Liquid fuel is injected by a nozzle which is located in the lower part of the combustion chamber. The initial temperature of the gas in the combustion chamber is 900 K, the fuel is injected at 300 K. The initial radius of the injected droplets is 25 microns.

Air was used as oxidant, stoichiometric composition of which was calculated by using the mass of used fuel. This air composition provides a complete combustion without of excessive oxidant residue. In internal combustion engines the oxidizing agent is atmospheric oxygen. An ordinary air is composed of 78% nitrogen and 21% oxygen, which are the predominant elements.

## NUMERICAL RESULTS

This work presents the results of numerical simulation of the octane and dodecane combustion depending on the oxidant's initial temperature in the combustion chamber. The initial optimal values of the pressure and mass were 6 bar and 100 mg for the octane and 80 bar and 7 mg for the dodecane, which have been identified in previous works [5, 9-13]. The initial temperature in the combustion chamber was varied from 700 to 1500 K. The results of numerical experiments of two kinds of liquid fuel combustion by using the statistical model of atomization are presented in this work.

In this work we measured the area of injection of liquid fuel spray in the combustion chamber. The investigation results are shown in Fig.2. This figure shows a comparison between the results of the numerical data and the experiment, which was staged by the authors of work [12]. The authors of work [12] used a diesel, the main component of which is tetradecane  $C_{14}H_{30}$ . As shown in Fig.2, the experimental points for diesel fuel (green line) and numerical calculations for dodecane (blue line) are consistent with each other better than the numerical calculations for octane (red line).

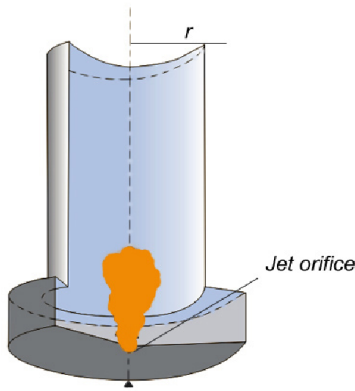

**Fig.1.** General view of the combustion chamber

Fig.3 shows the distribution of the maximum combustion temperature depending on the oxidant's initial temperature. Analysis of Fig.2 shows that if the oxidant's temperature in the combustion chamber takes values higher than 800 K, in this case the fuel burns intensively and the large amount of heat is generated and the combustion chamber is warmed up to 3000 K. The oxidant's initial temperature influences on the dodecane's combustion, since the increasing of the initial temperature from 900 to 1500 K leads to increasing of the maximum temperature from 2080.09 to 2684.69 K.

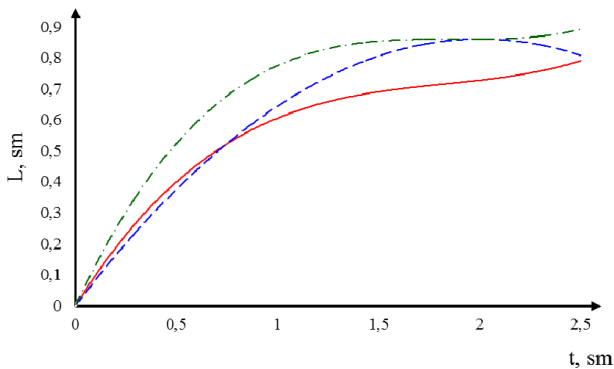

**Fig.2.** The injection area of liquid fuel spray in the combustion chamber (green line - diesel, blue line - dodecane, red line – octane)

Fig.4 shows the distribution of the maximum concentration of carbon dioxide for the two types of fuel (octane and dodecane) depending on the oxidant's initial temperature in the combustion chamber. During the dodecane's combustion the concentration of carbon dioxide takes higher values than the octane's combustion. As can be seen from the Fig.3, when the temperature increases from 900 K to 1500 K the concentration of carbon dioxide emitted by combustion of the octane reaches values from 0.08459 g/g to 0.08561 g/g and the combustion of dodecane from 0.11986 g/g to 0.14142 g/g.

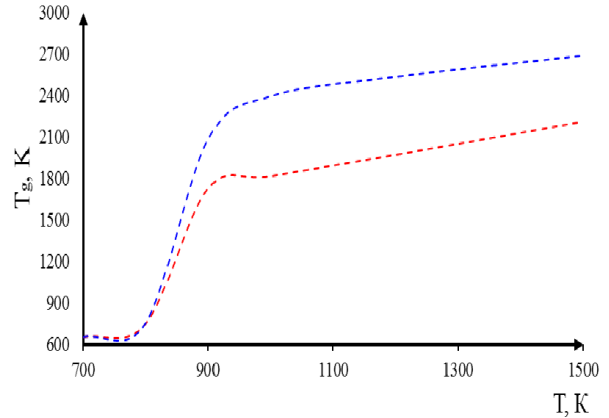

**Fig.3.** The dependence of the maximum combustion temperature on the oxidant's initial temperature in the combustion chamber during the combustion of octane and dodecane (red line is octane and blue line is dodecane)

From the analysis of the Fig.3 and Fig.4 it can be concluded that for the octane and dodecane the oxidant's optimal initial temperature in the combustion chamber begins with 900 K. Beginning from this value of the temperature the fuel reacts rapidly with the oxidant, the combustion chamber is warmed up to high values of temperature, and the concentration of generated carbon dioxide didn't exceed permissible limits.

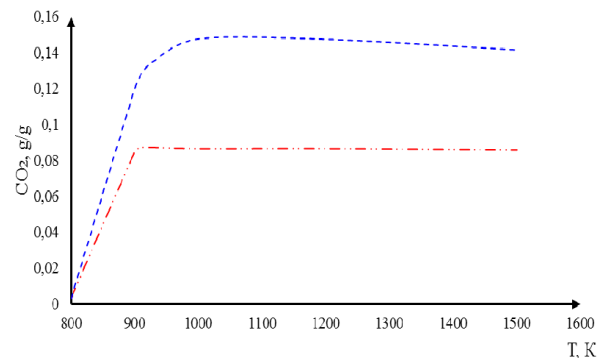

**Fig.4.** The dependence of the carbon dioxide's concentration on the oxidant's initial temperature in the combustion chamber during the combustion of octane and dodecane (red line is octane and blue line is dodecane)

This conclusion is supported by the two-dimensional distribution graphs of the basic parameters describing atomization, dispersion and combustion processes of two types of liquid fuel (octane and dodecane), which are listed below.

Fig.5 shows the temperature distribution in the combustion chamber for octane and dodecane at time  $t=2.5$  ms for oxidant's initial temperature of 900 K. From these figure it can be seen how the temperature changes in the combustion chamber at a given time. The maximum temperature in the

combustion chamber during octane's combustion is 1726 K, and for the dodecane its value is 2080 K.

Fig.6 shows the octane and dodecane droplets distribution by temperature at time  $t=2.5$  ms. At time  $t=2.5$  ms octane and dodecane droplets is concentrated in a small region of the width of the combustion chamber. Droplets rise up by the height of the combustion chamber to 0.45 cm during octane's combustion. During the combustion of the dodecane at time  $t = 2.5$  ms droplets of liquid fuel reaches the height of the chamber 0.4 cm.

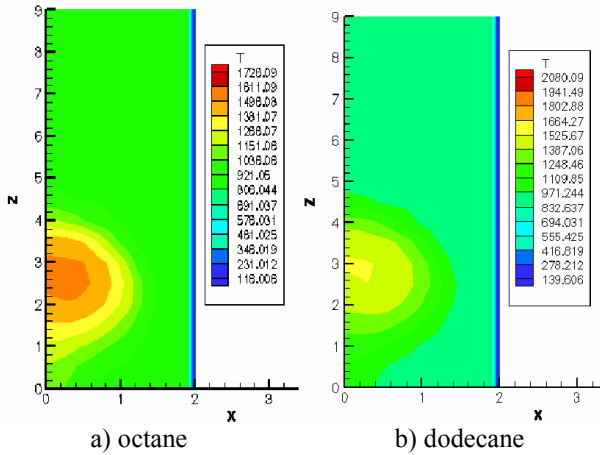

**Fig.5.** The distribution of the temperature in the combustion chamber for octane and dodecane at time  $t=2.5$  ms

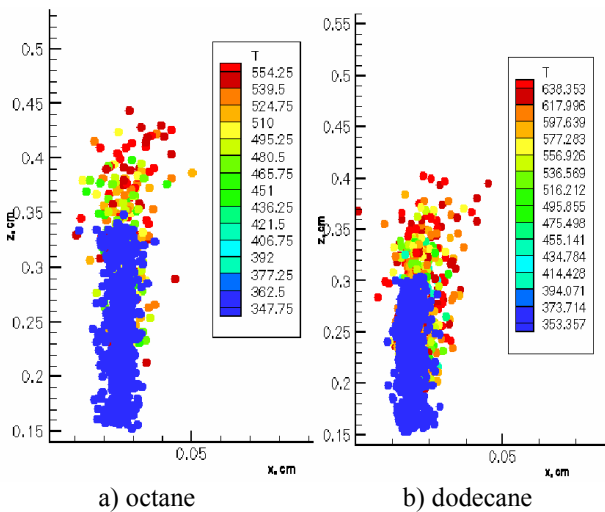

**Fig.6.** The distribution of the octane and dodecane droplets by the temperature at time  $t=2.5$  ms

In Fig.7 it is shown the results of numerical simulation of the carbon dioxide formation during the octane and dodecane combustion at the optimal temperature. The analysis of the figure shows that the maximum amount of the carbon dioxide for octane is formed on the axis of the combustion chamber and is equal to 0.08455878 g/g. During the

dodecane combustion on the axis of the combustion chamber concentration of carbon dioxide reaches a value equal to 0.103878 g/g. At the outlet of combustion chamber the concentration of carbon dioxide is reduced and takes minimum values for both fuels.

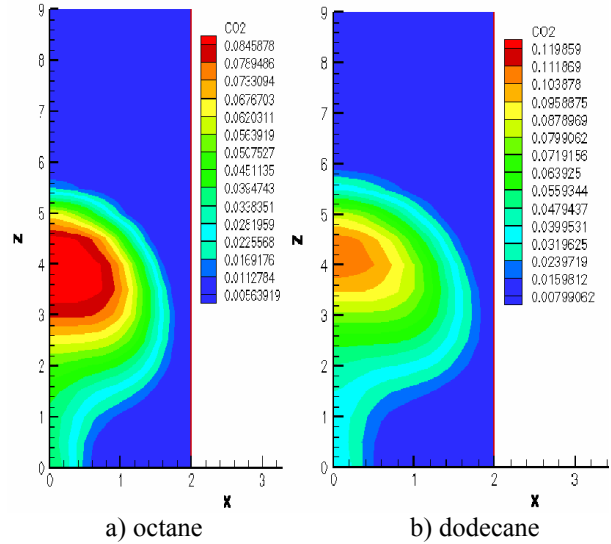

**Fig.7.** The distribution of the CO<sub>2</sub> concentrations in combustion chamber for octane and dodecane at time  $t=3$  ms

#### ACKNOWLEDGEMENT

This work was financially supported by the Ministry of Education and Science of the Republic of Kazakhstan – Grant №0115RK00599.

#### CONCLUSION

In this work numerical study of the influence of the oxidant's initial temperature on the combustion process of octane and dodecane was conducted. The optimal parameters for the fuel mass and pressure in the combustion chamber had been previously identified in the works of scientists, specializing in the modeling of two-phase flows [5, 9-13]. Also, similar studies have been conducted by various scientists who specialize in the field of modeling of two-phase reacting flows in real geometry areas. Various types of solid fuels are used by these authors, especially coals of Kazakhstan of various grades and ash content, which are burnt in thermal power stations and the various thermal centers of the country [14-20].

In this work it was shown that for the two types of liquid fuel the oxidant's optimal initial temperature in the combustion chamber is 900 K. Beginning from this temperature the fuel burns completely, the chamber is heated to the

sufficiently high temperature, and the produced concentration of carbon dioxide takes smallest value.

#### REFERENCES

- 1 Mayer D.O., *Business and Society Review*, 105, 347 (2000).
- 2 Askarova, S. Bolegenova, Bolegenova Symbat, I. Berezovskaya, Zh., Ospanova Sh., Shortanbayeva, A. Maksutkhanova, G. Mukasheva and A. Ergalieva, *J. of Engineering and Applied Sciences*, 10, 90 (2015).
- 3 Gorokhovski M., *Atomization and Sprays*, 1, 169 (2001).
- 4 Gorokhovski M.A., Saveliev V.L., *Physics of Fluids*, 5, 184 (2003).
- 5 Gorokhovski, M., Chtab-Desportes, A., Voloshina, I., Askarova (AIP Conf. Proc., Xian, 2010, p. 66-73).
- 6 Askarova, A. S., Karpenko, E. I., Karpenko, Yu. E., Messerle, V. E., Ustimenko, A. B. (7th International Fall Seminar on Propellants, Explosives and Pyrotechnics, Xian, 2007), Xian, 2007, p. 672-683.
- 7 Askarova A., Bolegenova S., Bekmukhamet A., Ospanova Sh., Gabitova Z., *Journal of Engineering and Applied Sciences*, 9, 24 (2014).
- 8 Ustimenko A.B., Askarova A.S., Messerle V.E., Nagibin, *Journal of Thermophysics and Aeromechanics*, 7, 435 (2010).
- 9 Askarova, A.S., Messerle, V. E., Ustimenko, A. B., Bolegenova, S. A., Maksimov, V. Yu., *Thermophysics and aeromechanics*, 21, 747 (2014).
- 10 Bolegenova, S.A., Maximov, V.Y., Bekmukhamet, A., Beketayeva, M.T. Gabitova, ZK., *High temperature*, 5, 751 (2015).
- 11 Askarova A.S., Bolegenova S.A., Berezovskaya I.E., Ospanova Sh. (Proceedings of the 2013 Int. conf. on Applied Mathematics and Computational Methods in engineering, Rhodes Islands, Greece, 2013), Rhodes Islands, Greece, 2013, p. 155-158.
- 12 Arcoumanis C., Cutter P., Whitelaw D. S., *Institution of Chemical Engineer Trans IChemE*, 76, 124 (1998).
- 13 Askarova, A.S., Voloshina, I.E., Ryspayeva, M.Zh. (Abstracts of V-th International conference "Problems of industrial heat engineering", Kiev, Ukraine, 2007), Kiev, Ukraine, 2007, p. 27-28.
- 14 Askarova, A. S., Messerle, V. E., Ustimenko, A.B., Bolegenova, S. A., Maximov, V. Yu. Gabitova, Z. Kh., *High temperature*, 53, 445 (2015).
- 15 Askarova, A., Maximov, V., Bolegenova, S., Beketayeva, M., Safarik, P., *Journal of thermal science*, 24, 275 (2015).
- 16 A. Askarova, A. Bekmukhamet, S. Bolegenova, S.Ospanova, B. Symbat, V. Maximov, M. Beketayeva, A. Ergalieva. 3-D Modeling of Heat and MassTransfer during Combustion of Solid Fuel in Bkz-420-140-7C Combustion Chamber of Kazakhstan. *J. Applied Fluid Mechanics*, 9, 699 (2016).
- 17 Karpenko E.I., Messerle V.E., Askarova A.S., *Journal of High Energy Chemistry*, 40, 111 (2006).
- 18 Messerle V.E., Lavrishcheva Ye.I., Karpenko E.I., Askarova A.S., Ustimenko A.B., *IEEE Transactions on Plasma Science*, 35, 1607 (2007).
- 19 Askarowa A., Buchmann M.A. (Gesell Energietechn, Combustion and incineration - Eighteenth Dutch-German Conference on Flames), *VDI Berichte*, 1997, vol.313, p. 241-244.
- 20 Vockrodt S., Leithner. R, Schiller A., Askarowa A.S. (VDI, 19th German Conference on Flames, Germany, VDI Gesell Energietechn; Verein Deutsch Ingn., Combustion And Incineration), *VDI Berichte*, 1999, vol. 1492, p. 93.