

## Research on protective method of ship electrostatic field based on metal polarization control

Wang Xiangjun, Liu Yi\*, Liu Dehong

*School of Electrical Engineering, Naval University of Engineering, 430033, China*

Received April 21, 2018; Accepted July 28, 2018

There is the electrochemical corrosion among different metals of the ship in the seawater, of which the foremost is the electrochemical corrosion between the steel hull and the bronze propeller. In this electrochemical corrosion process, the hull is the electrochemical corrosion anode, and the propeller is the electrochemical corrosion cathode. Besides, the corrosion current from the hull to the propeller current would generate around the ship. The corrosion current would form an electrostatic field in the seawater, and field signal is easily detected by the mine and detection equipment, which can bring a great threat to the ships. In this paper, based on the research on the metal polarization curve, the potential balance method combining the anode polarization of the hull and the cathodic polarization of the propeller is proposed, to make the potential difference reduce to 0V. At this point, the corrosion current can be also greatly reduced, and the associated underwater electric field can also be eliminated. It is demonstrated that the proposed method can reduce the underwater electrostatic field indeed, and the electric field protection effect is obvious.

**Keywords:** Cathodic polarization; Anodic polarization; Tafair formula; Polarization potential; Electrostatic field protection

### 1. INTRODUCTION

The ships are in service in seawater, of which different underwater metallic materials (such as hull, propeller, rudder, bulb, etc.) have different electrode potentials. For instance, the electrode potential of a commonly used marine steel plate is -0.64 V, and the potential of the copper propeller is -0.32 V. The present domestic ships are mainly shaft through ships, of which the propeller-shaft and the hull are in the electrical connection state [1]. In terms of the shaft through structure, the electrochemical corrosion between the propeller and the hull is inevitable, and a certain potential difference is maintained in the seawater. The potential difference forms a primary battery generating stable corrosion current via the conductive seawater, thus a steady state electric field is established. This macro-corrosion battery with complex structure is one of major origins of the underwater electric field generated by ships, of which the voltage is determined by the materials and the depolarization strength [2, 3].

In terms of China's ships, the sacrificial anode and the impressed current cathodic protection methods are adopted to protect the hull from corrosion. However, both of aforementioned methods would increase the strength of the electric field around the ship and reduce the ship stealth [4, 5].

According to some projections, the total sacrificial anode protection current intensity of a medium-sized ship can reach hundreds or even thousands of amps. Due to the great intensity of the protection current, the strong electrostatic field around the ships can be generated even if the electrodes are closer to each other.

There are few auxiliary auxiliaries in the impressed current cathodic protection system, and the protection current density is generally greater than the sacrificial anode indicators (such as 10 ~ 60mA/m of the the painting hull), and therefore the stronger electric field would be generated around the ship hull [6]

The shaft cutting technology applied to the Russian ships make the propeller and the hull form a direct electrical connection state without the macroaxis, which greatly reduces the corrosion current, and the underwater electric field around the ship is reduced thereby. The China's present macoraxis manufacturing level determines that shaft cutting state can be achieved, and therefore China's ships cannot use Russia's electric field protection methods for reference. Based on this background, it is very necessary to propose an active protection method that is suitable for homemade ships, which not only can protect the hull from corrosion, but also can reduce the strength of the underwater electric field around the ships.

---

\* To whom all correspondence should be sent:  
E-mail: liuyi8888a@163.com

## 2. THE ANODE POLARIZATION AND CATHODIC POLARIZATION POTENTIAL VARIATION LAW OF HULL-PROPELLER

Each metal in the seawater has a certain electrode potential: the metal surface partial ions would be affected by the water polar molecule in the process of contacting with the electrolyte solution, and a "double electrode layer" would generate at the interface, causing the potential difference between the metal and seawater. The metal with different electrode potentials in the electrolyte solution can form a corrosion current loop when there is an external electrical connection, which results in the occurrence of electrochemical corrosion [7]. In this process, the electrode where an oxidation reaction (lose electrons) is performed is referred to as an anode, and the electrode where a

reduction reaction (obtain electrons) is performed is referred to as a cathode. As shown in Figure.1, in the process of ship's electrochemical corrosion, the steel hull (electrode potential is negative) is the anode of electrochemical corrosion, and the bronze propeller (electrode potential is positive) is the cathode of electrochemical corrosion [8].

The corrosion current flows from the hull to the propeller in the seawater, and the ship's electrostatic field is formed. As a result of the propeller rotation, the contact resistance between the hull and the propeller changes periodically, and the modulated corrosion current generates a periodically varying shaft-frequency electric field. Therefore, the ship's corrosion current is the main source of the ship's electrostatic field and the shaft-frequency electric field [9].

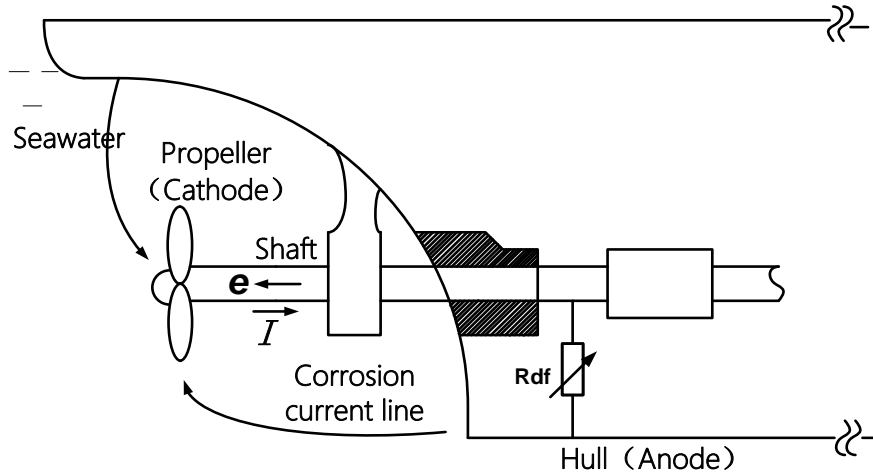

Fig.1. Schematic diagram of electrochemical corrosion of naval vessels.

In the process of the aforementioned metal electrochemical corrosion, the corrosion current would cause the electrons to move, and the electrode polarization would occur in the hull and the propeller: the electrons on the hull (anode) would flow into the propeller (cathode) through the main axis, resulting in a decrease in the electric charge density of the electric double layer on the hull, while the charge density of the electric double layer on the propeller would increase [10].

In this way, the potential of the anode (hull) gradually moves in the positive direction (anode polarization), and the potential of the cathode (propeller) gradually moves in the negative direction (cathode polarization). In the process of polarization, the potential difference between the

hull and the propeller is gradually reduced, and the corrosion current in the circuit is gradually reduced. The polarization causes the electrochemical corrosion to slow down. However, the degree of the natural electrode polarization to reduce electrochemical corrosion is relatively weak, and electrochemical corrosion cannot be eliminated [11].

If the electrode polarization can be controlled artificially to decrease the potential difference between the hull and the propeller to 0V, the potential balance would be realized; the corrosion current would disappear, and the associated underwater electric field would also be eliminated. The potential polarization balance is shown in Figure 2.

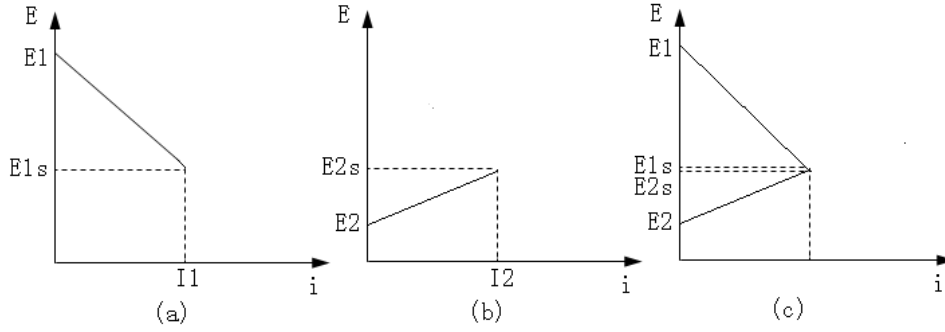

**Fig.2.** Potential balance polarization diagram. (a) propeller cathodic polarization; (b) Hull anodic polarization; (c) potential balance)

The polarization reaction of the metal electrode can be expressed by the Tafel formula:

$$I = I_a - |I_c| = I_{0,a} \exp\left(\frac{E - E_{e,a}}{\beta_a}\right) - I_{0,c} \exp\left(-\frac{E - E_{e,c}}{\beta_c}\right) \quad (1)$$

Where  $I$  is polarization current density,  $I_{0,a}$  and  $I_{0,c}$  are exchange current density of metal anodic dissolution reaction and cathodic reduction reaction respectively.  $E_{e,a}$  and  $E_{e,c}$  are balance potentials of metal anodic dissolution reaction and cathodic reduction reaction respectively;  $\beta_a$  and  $\beta_c$  are Tafel slopes of metal anodic dissolution reaction and cathodic reduction reaction respectively.

In the case of  $I=0$ , the metal does not produce polarization reaction, and its potential is the metal corrosion potential  $E_{corr}$ . At this time, the absolute value of the current density of the metal anode reaction is equal to the absolute value of the current density of the cathode reaction, which is also equal to the metal average corrosion current density  $I_{corr}$ :

$$I_{0,a} \exp\left(\frac{E_{corr} - E_{e,a}}{\beta_a}\right) = I_{0,c} \exp\left(-\frac{E_{corr} - E_{e,c}}{\beta_c}\right) = I_{corr} \quad (2)$$

Based on the Eq.(1) and Eq.(2), the Eq.(3) can be obtained as follows:

$$I = I_{corr} \left[ \exp\left(\frac{E - E_{corr}}{\beta_a}\right) - \exp\left(-\frac{E - E_{corr}}{\beta_c}\right) \right] \quad (3)$$

The Eq.(3) is the  $E-I$  curve (polarization curve) equation of the corrosion metal electrode. The  $E_{corr}$  is assumed as the origin of axis  $E$ , and then the coordinates of  $E$  axis is changed to  $\Delta E$ :

$$\Delta E = E - E_{corr} \quad (4)$$

In fact,  $\Delta E$  is the metal polarization potential value after polarization based on the corrosion potential. In the case of  $\Delta E=0$ , there is no polarization reaction about metal;  $\Delta E>0$ : the metal is subjected to anodic polarization reaction;  $\Delta E < 0$ : the metal is subjected to cathodic polarization reaction.

Based on the Eq.(3) and Eq.(4), the following formula can be obtained through the further mathematical operation:

$$I = I_{corr} \left[ \exp\left(\frac{\Delta E}{\beta_a}\right) - \exp\left(-\frac{\Delta E}{\beta_c}\right) \right] \quad (5)$$

In the process of metal cathodic polarization, the polarization rate is not only determined by the electrochemical process on the metal surface, but also the depolarization diffusion process in the solution. In this case, the relationship between the absolute value of cathode current density and electrode potential is:

$$|I_c| = \left( 1 - \frac{|I_c|}{I_L} \right) I_{0,c} \exp\left(-\frac{E - E_{e,c}}{\beta_c}\right) \quad (6)$$

Where  $I_L$  is the absolute value of the diffusion current density of the cathode reaction. In the case of  $E = E_{corr}$ , the Eq.(7) can be deduced from the Eq.(4) and Eq.(6):

$$|I_c| = \frac{I_{corr} \exp\left(-\frac{\Delta E}{\beta_c}\right)}{1 - \frac{I_{corr}}{I_L} [1 - \exp\left(-\frac{\Delta E}{\beta_c}\right)]} \quad (7)$$

Then, the metal polarization equation considering depolarization diffusion process can be obtained as follows:

$$I = I_{corr} \left\{ \exp\left(\frac{\Delta E}{\beta_a}\right) - \frac{I_{corr} \exp\left(-\frac{\Delta E}{\beta_c}\right)}{1 - \frac{I_{corr}}{I_L} [1 - \exp\left(-\frac{\Delta E}{\beta_c}\right)]} \right\} \quad (8)$$

The polarization experiment is performed on a certain type of high-strength steel for marine, to compare the experimental results with the theoretically calculated Tafir curve, which is shown in Fig.3.

From Fig.3, it is can be learned that the polarization curve is basically consistent with the theoretical Tafir curve. As a result, the Tafir formula can be used as the basis for the research on the polarization of the hull and propeller.

### 3. POTENTIAL BALANCE ELECTRIC FIELD PROTECTION EXPERIMENTAL COUNTER DESIGN

On the basis of theoretical research, the electric field protection experimental prototype is developed, which is based on the potential balance principle [12]. By means of the auxiliary electrodes

arranged at different parts of hull, the anodic polarization is performed to the hull, and cathodic polarization is performed to the propeller, to ensure that the potential difference between the hull and propeller keeps constant at 0V. Fig.4 presents the design principle of the electric field protection experimental prototype [13].

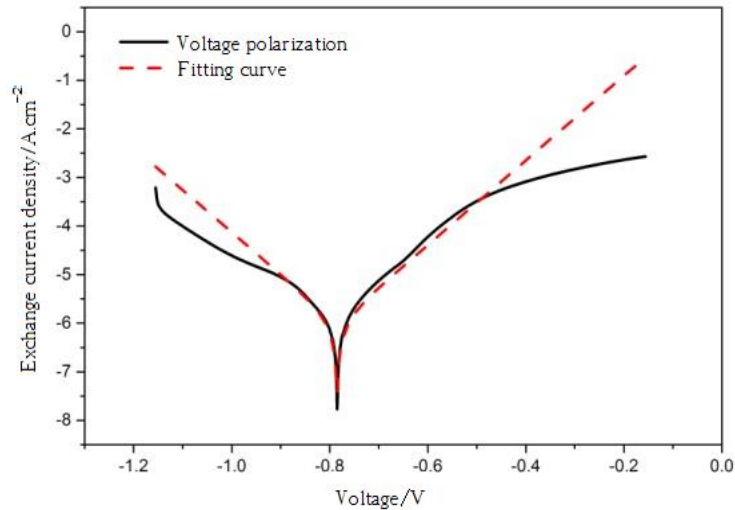

Fig.3. Fitting of polarization curve and Tafir curve of high strength steel of ship.

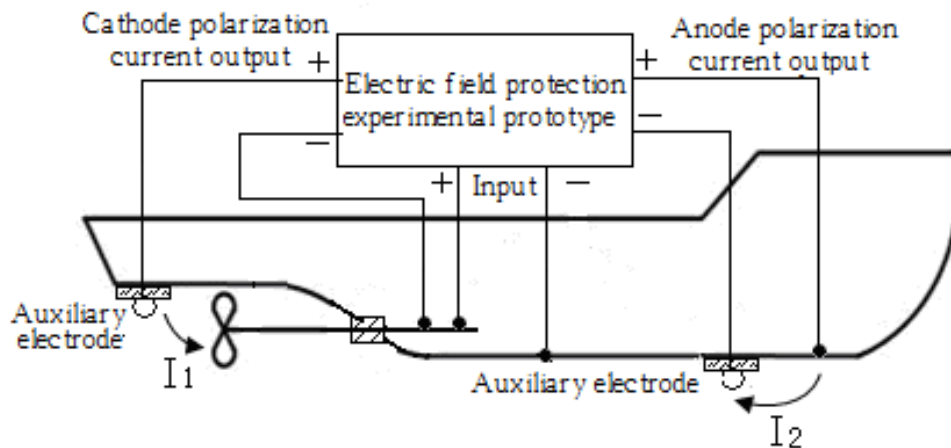

Fig.4. Design schematic diagram of experimental prototype for electric field protection.

The potential difference between the hull and the propeller is used as the control signal, to control the anodic polarization current and the cathodic polarization current outputting from the electric field protection prototype. When the potentials of propeller and hull are close, the corrosion current would disappear, and the underwater electric field would eliminate [14, 15].

The operating principle of the electric field protection experimental prototype is presented as follows:

The potentiometric signal of the main axis relative to the hull flows from the contact brush

device to input port of the electric field protection test prototype, and two sets of current would output from the controlled port of the electric field protection prototype: 1, The anode polarization current flows from the hull to the auxiliary electrode through the sea, which will flow back to the electric field protection test prototype finally; 2, The cathode polarization current flows from the auxiliary electrode to the propeller through the sea, which will flow back to the electric field protection test prototype through the main axis .

The electric field protection experimental prototype composition diagram is shown in Figure 5, which mainly contains the following parts:(1) Potential detection device; (2)

Polarization current output control device; (3) Controllable constant current source (4) Polarization current output electrode.

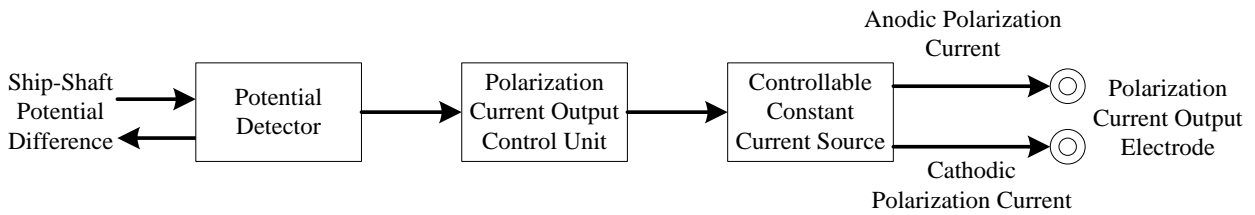

Fig.5. The composition diagram of electric field protection experiment prototype.

#### 4. EXPERIMENTAL STUDY ON UNDERWATER ELECTROSTATIC FIELD PROTECTION OF SHIP MODEL POTENTIAL BALANCE

##### 4.1 Experimental program

The ship model potential balance and electromagnetic field protection experiment is based on the simultaneous anodic polarization of the hull and cathodic polarization of the propeller, which can make the potential difference between the hull and the propeller equal zero, to measure the change of the electric field around the ship model. The experiment is based on two cases of propeller rotating or not, to obtain electric field measurement data before and after performing electrostatic field protection, which is used to measure the protection effectiveness.

##### 4.2. Experimental preparation

The experiment is carried out in a non-magnetic electric field pool, and the length, width and depth of the pond are set to 8 m, 5 m and 1.5 m respectively. The experimental sea water with depth of 0.6m is poured into the pool, combined with the industrial salt to make the conductivity of the sea water equal 3.8s/m.

A set of Ag-AgCl electrodes with three-component are placed at the bottom of the pool, to measure the electric field values of  $E_x$ ,  $E_y$  and  $E_z$ , and calculate the electric field module values. The immersion time of electric field sensor is set to 24 hours.

Based on the ship model drag device, the experimental ship model is expected to be in uniform motion state in the experimental pool, and the three-component electric field sensor would

measure the passing characteristic curve of the experimental ship model.

##### 4.3. Experimental Results

The experimental process is based on the ship model's forward and backward uniform movement in the experimental pool with the length of 8 meters. Given that the confidentiality of experimental data, the electric field values of given graphics have been treated, which would not affect the judgment of the electrostatic field protection effect after adopting the potential balance electrostatic field protection method.

According to the characteristics of the underwater electrostatic field of the ship, the electric field module value  $|E|$  contains the three components of the electric field value, which can reflect the protective effect more accurately, so that the electric field module  $|E|$  can be used as the evaluation criteria.

**The electrostatic field protection experiment in the case of non-rotating propeller.** In the case of propellers not rotating, the three-component electric field values before and after adopting potential balance protection method are used for experimental verification, and the variation of  $|E|$  is presented as Fig.6 shows. The ordinate in the Fig.6 is the processed electric field value, the abscissa represents time, the upper right corner is the curve explaining, and the number is the time of measurement.

The electrostatic field value and module value of each component as well as the protective effect are shown in Table 1.

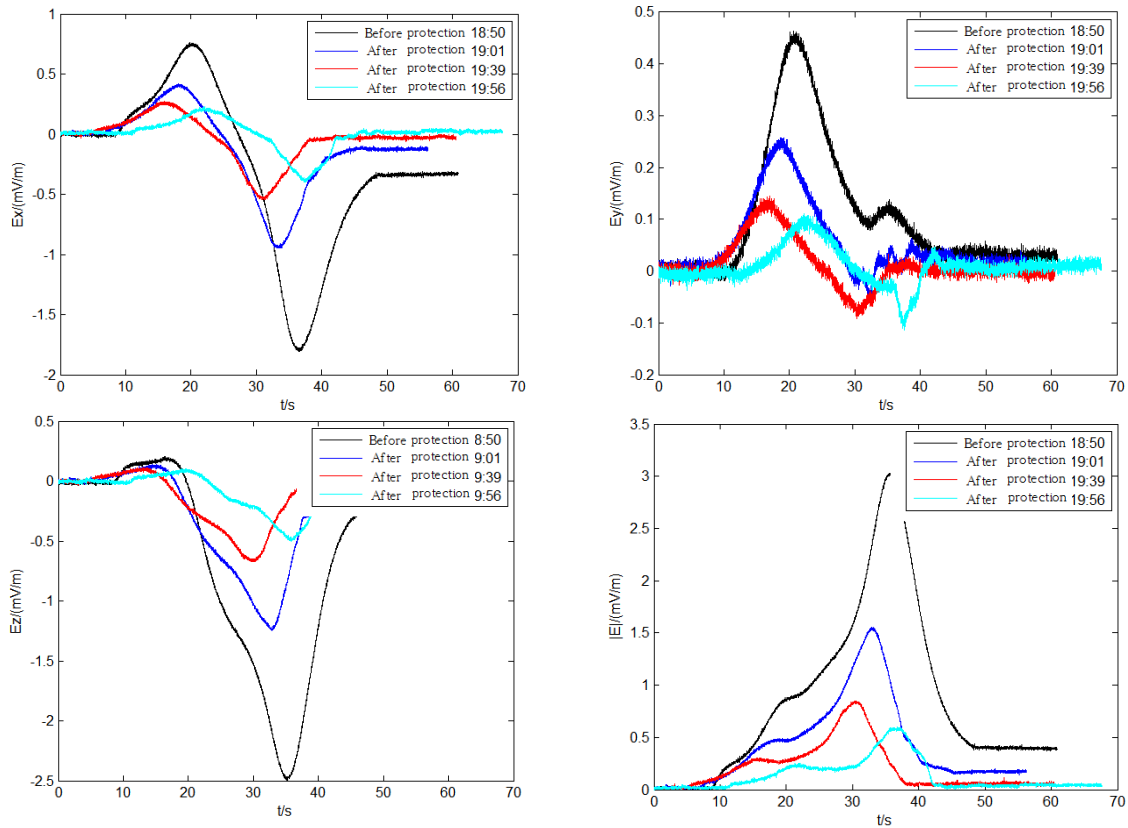

Fig.6. The propeller does not rotate, electrostatic field values of natural corrosion and invisible.

Table 1. The propeller does not rotate, electrostatic field value of ship model and its protective effect.

Time	18:50	19:01	19:39	19:56
Ex (Peak-to-Peak Value)	2.57	1.37	0.82	0.63
Ex(Decreasing Proportion) (%)		46.73	68.00	75.57
Ey(Peak-to-Peak Value)	0.48	0.31	0.24	0.22
Ey (Decreasing Proportion) (%)		34.85	51.04	53.53
Ez(Peak-to-Peak Value)	2.70	1.38	0.79	0.61
Ez(Decreasing Proportion) (%)		48.76	70.78	77.57
E (Peak-to-Peak Value)	3.03	1.55	0.85	0.60
E  (Decreasing Proportion) (%)		48.67	71.94	80.22

There are some analysis from the aforementioned experimental results

- 1) Based on the electrostatic field protection method with potential balance, three components of the electric field values and electric field model values at the same test point have been significantly reduced. Once the potential balance protection test prototype is initiated, the electric field modulus  $|E|$  would be reduced by 48%; after one hour of polarization, the electric field modulus  $|E|$  would be reduced by 80%, and the protective effect is demonstrated;
- 2) The electric field three-component and module characteristic curve dose not change after adopting the electrostatic field protection method

with potential balance, which shows that the method would not change the electrostatic field distribution characteristic of the ship model, but only reduces the numerical value.

- 3) From Fig.5, it can be concluded that the longer the polarization is applied, the better the electrostatic field is. The reason for the aforementioned phenomenon is that the polarization is a dynamic variation process, and it would take some time to reach the dynamic equilibrium state, which is in accordance with the theoretical analysis results.

**The electrostatic field protection experiment in the case of propeller rotating ( $v=100r/min$ ).** In the case of propellers rotating with velocity of 100

r/min (to simulate the actual navigational status of ships), the three-component electric field values before and after adopting potential balance

protection method are used for experimental verification, and the variation of  $|E|$  is presented as Fig.6 shows.

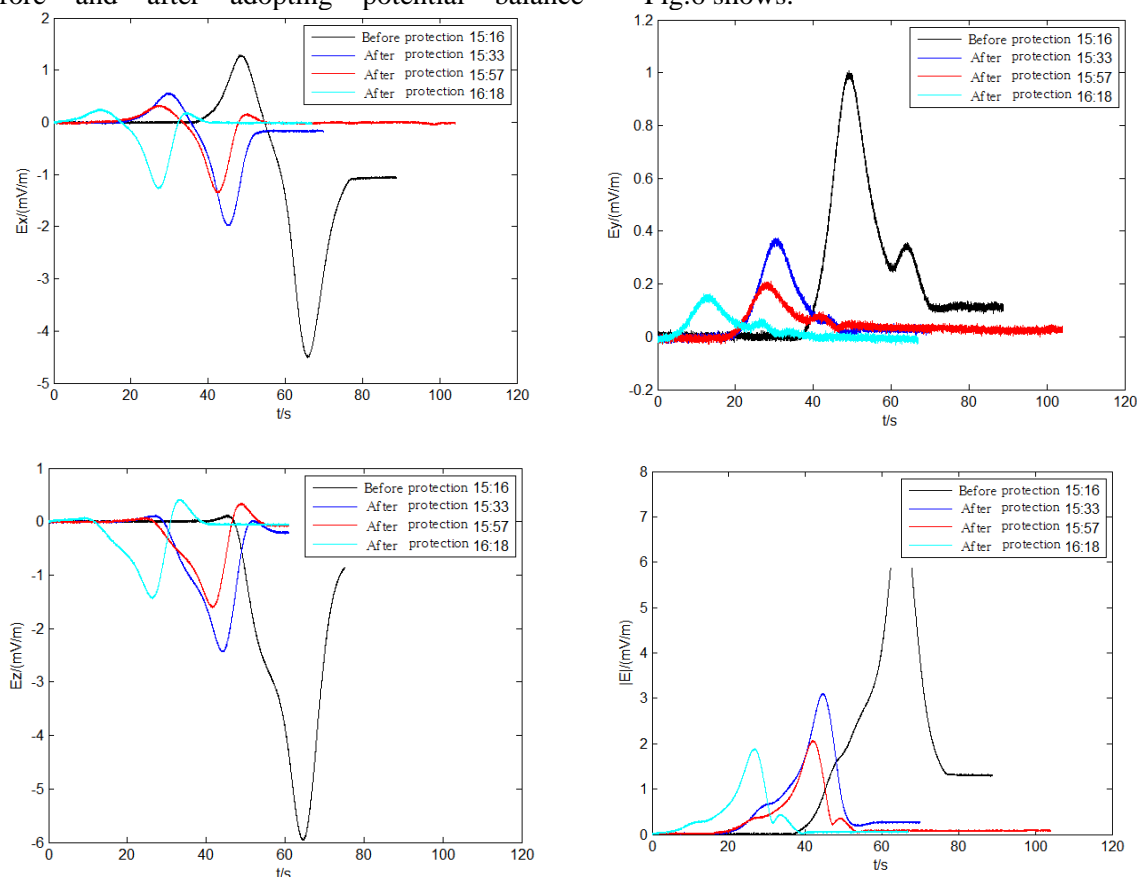

Fig.7. Propeller speed is 100r/min, electrostatic field values of natural corrosion and invisible.

Table 2. The propeller speed is 100r/min, electrostatic field value of ship model and its protective effect

Time	15:16	15:33	15:57	16:18
Ex (Peak-to-Peak Value)	5.80	2.55	1.68	1.53
Ex(Decreasing Proportion) (%)		56.00	70.99	73.70
Ey(Peak-to-Peak Value)	1.03	0.40	0.24	0.19
Ey (Decreasing Proportion) (%)		60.89	76.56	81.23
Ez(Peak-to-Peak Value)	6.09	2.56	1.95	1.86
Ez(Decreasing Proportion) (%)		57.93	67.89	69.52
$ E $ (Peak-to-Peak Value)	7.38	3.10	2.07	1.90
$ E $ (Decreasing Proportion) (%)		57.97	71.94	74.33

There are some analysis from the aforementioned experimental results

1) Based on the electrostatic field protection method with potential balance, three components of the electric field values and electric field model values at the same test point have been significantly reduced. Once the potential balance protection test prototype is initiated, the electric field modulus  $|E|$  would be reduced by 57%; after one hour of polarization, the electric field modulus  $|E|$  would be

reduced by 74%, and the protective effect is demonstrated;

2) The electric field three-component and module characteristic curve dose not change after adopting the electrostatic field protection method with potential balance; there is only some difference between the start time of measuring and ship model moving, which makes each curve has a certain translation on the time axis.

3) From Fig.7, it can be concluded that the longer the polarization is applied, the better the electrostatic field is.

4) The final protective effect of the experiment in the case of propeller rotating is only 74%, which is worse than the protective effect in the case of propeller not rotating. The reasons for the experimental results are presented as follows: After propeller rotating, the propeller cathodic polarization process is more complicated due to the periodic change of the contact resistance near the propeller; As a result of the simultaneous opening of the axial frequency protection equipment, the additional axial frequency protection current would generate between the shaft and shell, which make has an effect on the polarization process

## 5. CONCLUSION

On the basis of research on the hull-propeller metal polarization law, the naval vessel electric field protection method based on the potential balance is proposed in this study. Then, the experimental prototype is designed to carry on the electrostatic field protection experiment in the experimental pool, and the experimental results are analyzed further. Finally, the electric field protection control method is analyzed.

The experimental results show that the ship model electrostatic field can be reduced by more than 70% based on the proposed method, and the electrostatic field protection effect is demonstrated. In addition, once the axial frequency electric field protection device is initiated, the electrostatic field protection effect would get worse, and how to strike a balance would be the focus of further study.

It is noted that the method of controlling the polarization current level to achieve a better potential balance is the key to achieve the electric field protection. In the further study, it is

considered to lay out the reference electrode to achieve polarization current controlling, of which signal can be used to judge the potential balance state.

**Acknowledgement.** The authors are grateful for the support provided for his study by the National Natural Science Foundation of China (NSFC-41476153).

## REFERENCES

1. Gong S., Lu X., *J. Naval Univ. Eng.*, **2**, 1 (2008).
2. Li J., Bao Z.H., Gong S.G., Hu P., Wu J.H., Xing S.H., *J. Naval Univ. Eng.*, **23**, 67 (2011).
3. Cao Y., Ji D., Zhu W.B., *Ship Sci. Technol.*, **37**, 69 (2015).
4. Zang Y., Yue R., Li P., *Ship Sci. Technol.*, **34**, 11 (2012).
5. Liu Y., Wang X.J., *Total Corrosion Control*, **31**, 38 (2017).
6. F.C. Walsh, G. Kear, A.H. Nahle., *Corrosion Sci.*, **123**, 1 (2017).
7. Wang H., Yang K., Zheng K., *J. Electromagn. Waves Appl.*, **29**, 858 (2015).
8. Ji D., Wang X.J., Liu Y., Liu D.H., *J. Sichuan Ordn.*, **35**, 4 (2014).
9. Wu Z.Q., Zhu X.H., Li B., *Sensor & Transducers*, **186**, 161 (2015).
10. I. Danaee, M.N. Khomami, A.A. Attar, *J. Materials Sci. Technol.*, **29**, 89 (2013).
11. Sun J.Z., Jiang H.L., Xia Z.S., *Appl. Mech. Materials. Trans Tech Publications*, **602**, 2649 (2014).
12. Jiang H.L., Zhang H.P., Xia Z.S., *Appl. Mech. Materials. Trans Tech Publications*, **563**, 333 (2014).
13. Zhang H.P., Chen X.G., Ao C.Y., *Appl. Mech. Materials. Trans Tech Publications*, **527**, 172 (2014).
14. Jia Y., Jiang R., Gong S., *Acta Armamentarii*, **5**, 11 (2013).
15. Jia Y., Jiang R., Gong S., *J. Shanghai Jiaotong Univ.*, **7**, 3 (2013).

## ИЗСЛЕДВАНЕ НА ЗАЩИТЕН МЕТОД ОТ ЕЛЕКТРОСТАТИЧНОТО ПОЛЕ НА КОРАБИ, ОСНОВАН НА ПОЛЯРИЗАЦИОННИЯ КОНТРОЛ НА МЕТАЛИТЕ

Ван Сянгджун, Лю И\*, Лю Дехонг

*Училище по електро-инженерство, Морски инженерен университет, Китай*

Постъпила на 21 април, 2018 г.; приета на 28 юли, 2018 г.

Известна е електрохимичната корозия сред различните метали при корабите в морска вода, като най-значителна е тази между стоманения корпус и бронзовото витло. При този електрохимичен корозионен процес корпусът е анод, а витлото – катод. При това се генерира корозионен ток, а заедно с това и електростатично поле в морската вода, което лесно се открива от мини и откриващи съоръжения, които са голяма заплаха за корабите. В настоящата работа е предложен метод за изравняване на потенциалите между корпуса и витлото, основан на кривите на поляризация на металите и комбинирайки анодната и катодната поляризацията. По този начин корозионният ток силно се намалява, а свързаното с него подводно електрично поле може също да се елиминира. Показано е, че с предложениия метод се намалява подводното електрично поле, а защитният ефект срещу корозия е очевиден.